



V. ORLANDI

SAF-HOLLAND Group

# V. ORLANDI

TOWING SYSTEMS since 1859

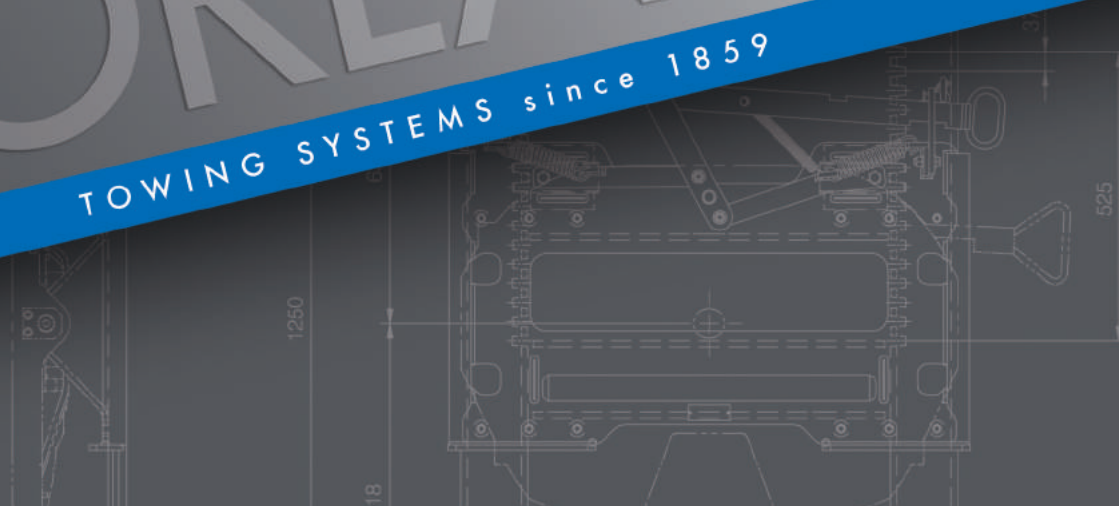

## PRODUCT CATALOGUE

ORIGINAL SPARE PARTS

FIFTH WHEELS  
BALL RACES  
KINGPINS  
LANDING GEAR

Edition 2021

Release 24

**SAF** *Holland*  
Group









[www.orlandi.it](http://www.orlandi.it)



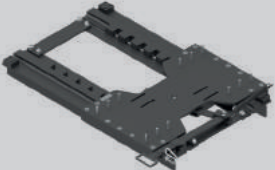

Check for the last update

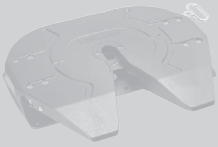
## Indice generale - General index

	<p>Ralle 2" <i>Fifth wheels 2"</i></p>	<p>4</p>
	<p>Ralle 3,5" - 4" <i>Fifth wheels 3,5" - 4"</i></p>	<p>19</p>
	<p>Piastre di avanzamento ralla <i>Fifth wheels slider</i></p>	<p>27</p>
	<p>Ralle a sfera <i>Ball races</i></p>	<p>32</p>
	<p>Perni di articolazione <i>Kingpins</i></p>	<p>34</p>
	<p>Sollevatori telescopici <i>Landing gear</i></p>	<p>36</p>
	<p>Prodotti fuori produzione <i>Out of production</i></p>	<p>39</p>

## Ralle 2" - Fifth wheels 2"

### INDICE - INDEX

	Perni di articolazione <i>Kingpins</i>	Omologazione <i>Homologation</i>	Descrizione <i>Description</i>	Pagina <i>Page</i>
<p>RV10</p> 	2"	ECE R55	Ralla su tamponi <i>Fifth wheel on rubber mounting</i> - bolt on	6
<p>RS08</p> 	2"	ECE R55	Ralla su perni <i>Fifth wheel on pivot mounting</i> - bolt on	8



# Ralle 2" - Fifth wheels 2"

## INDICE - INDEX

	Perni di articolazione <i>Kingpins</i>	Omologazione <i>Homologation</i>	Descrizione <i>Description</i>	Pagina <i>Page</i>
<p>FDH</p> 	2"	ECE R55	Ralla doppia altezza <i>Height-adjustable fifth wheel</i>	10
<p>FPX</p> 	2"		Ralla sollevatrice <i>Lifting fifth wheel</i>	14
<p>RP10 - K</p> 	2"	ECE R55	Ralla compensata <i>Compensated fifth wheel</i>	16



# RV10

Ralla su tamponi  
Fifth wheel on rubber mounting - bolt on

2"

Omologazione  
Homologation

ECE R55

## Dati tecnici - Technical data

Codice Part number	Altezza H H-Height [mm]	Valore D D-Value [kN]	Carico verticale U Imposed load [t]	Peso Weight [kg]	Omologazione Homologation		
					Classe Class	ECE R55	Tipo Type
F2T2G20V	150	152	22	147	G50-X	E11 01-10381	RV10
F2T2G30V	185	152	22	151	G50-X	E11 01-10381	RV10
F2T2G40V	250	152	22	164	G50-X	E11 01-10381	RV10

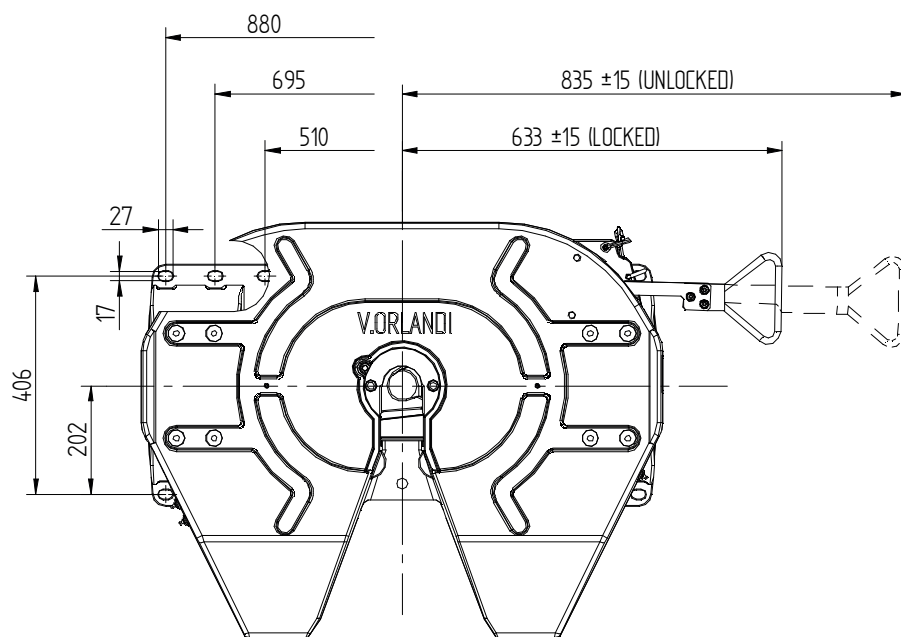
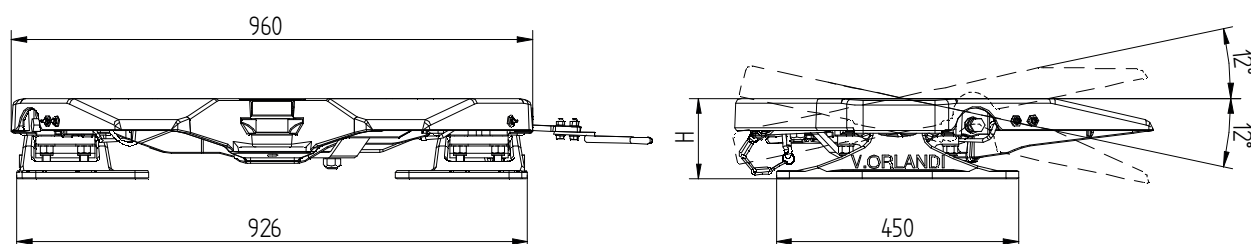

## Spare parts RV10



SAF-HOLLAND Group

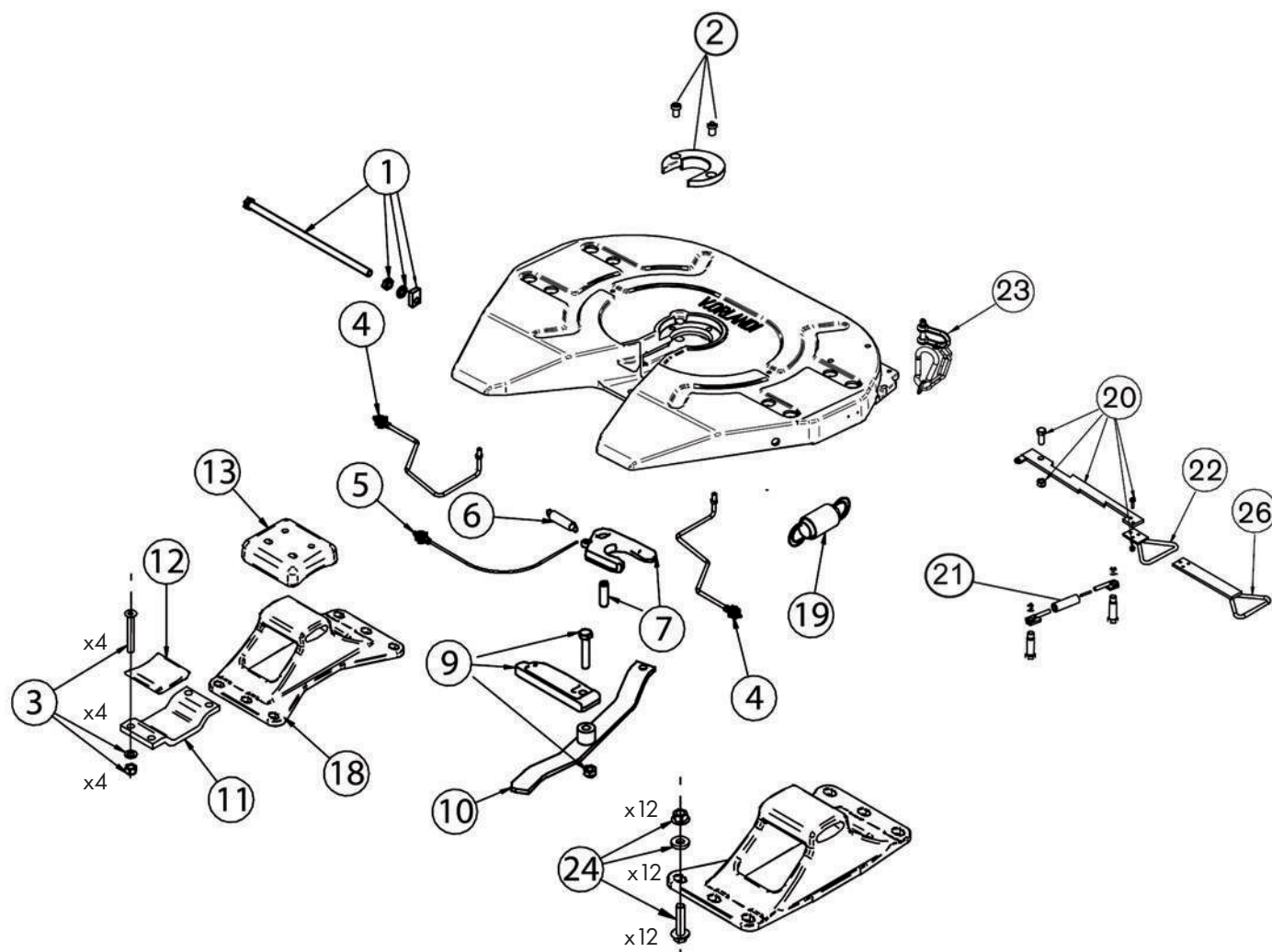

POS.	Tutti i tipi All types	Codice - Part number		
		F2T2G20V	F2T2G30V	F2T2G40V
1	RR00271			
2	RR00055			
3	RR00019			
4	RR00272			
5	RR00273			
6	RR00058			
7	RR00089			
9	RR00090			
10	RR00274			
11	RR00007			
12	RR00006			
13	RR00005			
18		RR00072	RR00073	RR00275
19	RR00037			
20	RR00276			
21	RR00048			
22	RR00079			
23	RR00278			
<b>KIT</b>				
24	RR00050			
2 - 6 - 7	RR00277			
(3 - 12 - 13) x2	RR00031			
26	RR00083			

# RS08

Ralla su perni  
Fifth wheel on pivot mounting - bolt on



2"

Omologazione  
Homologation

ECE R55

## Dati tecnici - Technical data

Codice Part number	Altezza H H-Height [mm]	Valore D D-Value [kN]	Carico verticale U Imposed load [t]	Peso Weight [kg]	Omologazione Homologation		
					Classe Class	ECE R55	Tipo Type
FSP1G10	150	152	20	128	G50-X	E11 01-5489	RS08
FSP1G30	185	152	20	130	G50-X	E11 01-5489	RS08
FSP1G40	218	152	20	135	G50-X	E11 01-5489	RS08

NOT SUITABLE FOR STEERING WEDGE

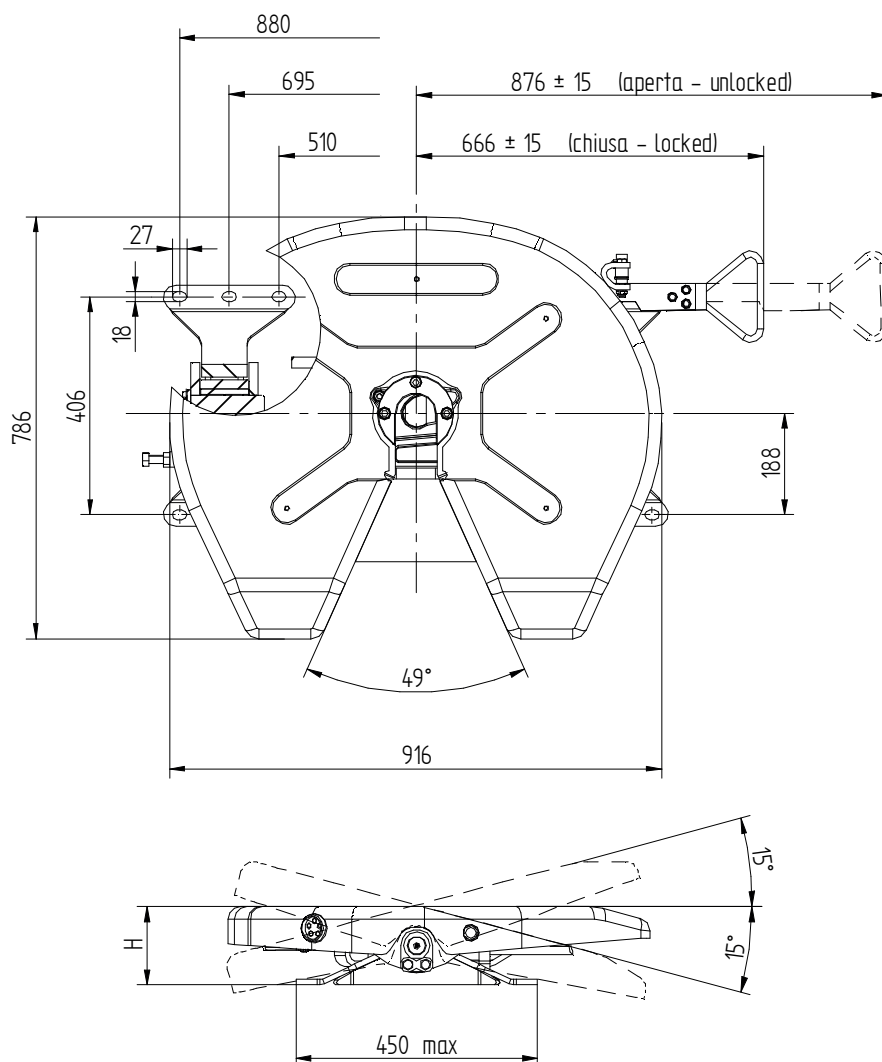

**Crea il tuo codice:**  
**Create your part number:**

**FSP1 G XX**

Tipo piatto - Top plate type

Altezza - Height - H

**Tipo piatto - Top plate type**

G = Ingrassato - Grease top

**Altezza - Height - H**

10 = 150 mm

30 = 185 mm

40 = 218 mm

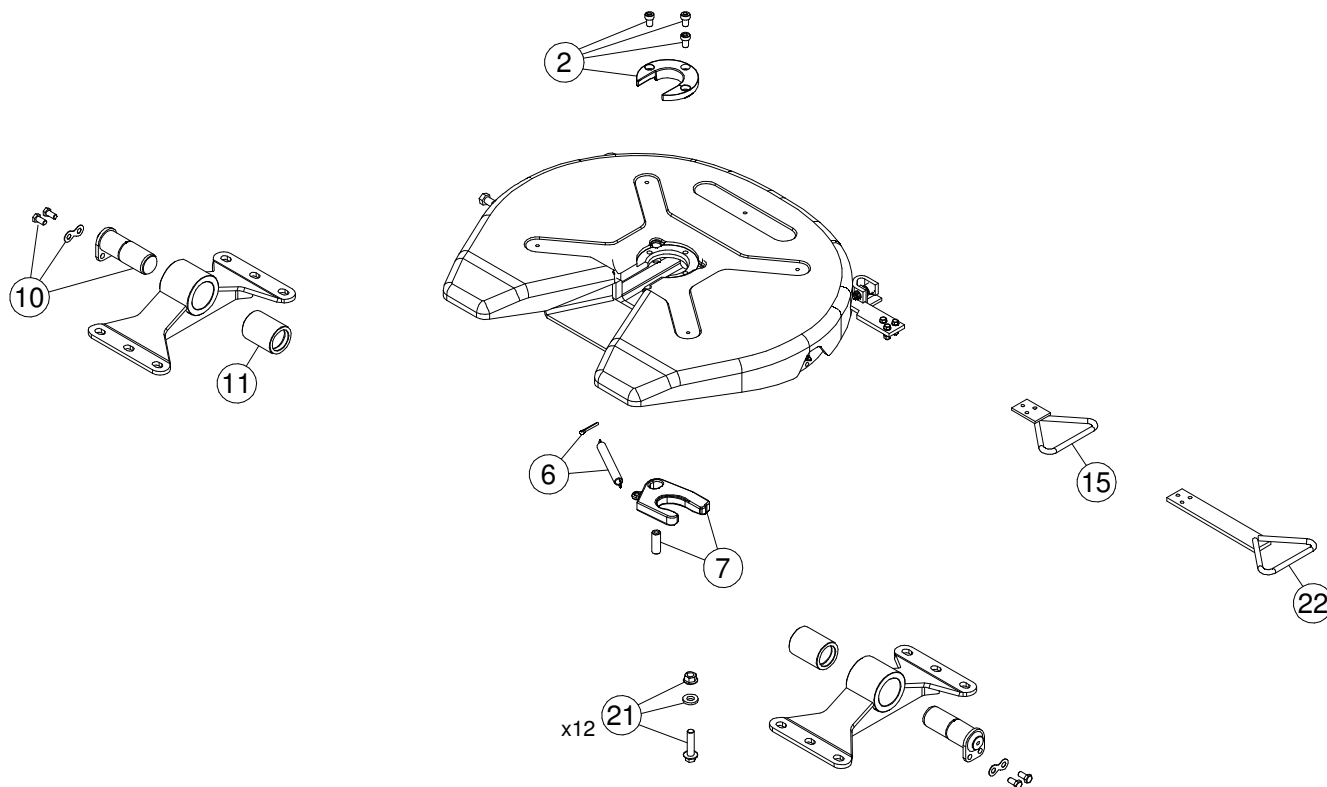

POS.	Tutti i tipi All types
10	RR00092
11	RR00093
15	RR00079
<b>KIT</b>	
21	RR00050
22	RR00083
2 - 6 - 7	RR00101

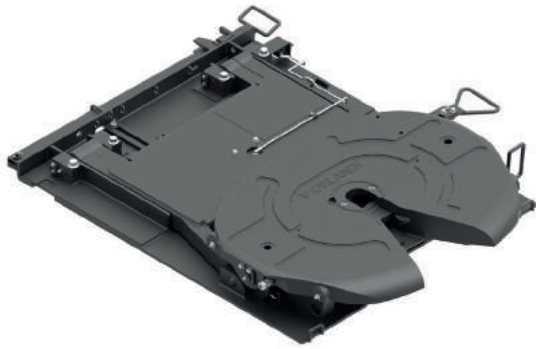

# FDH

Ralla doppia altezza  
Height-adjustable Fifth wheels

2"

Omologazione  
Homologation

ECE R55

## Dati tecnici - Technical data

Codice Part number	Altezza H H Height [mm]	Carico verticale U Imposed load [t]	Valore D D-Value [kN]	Peso Weight [kg]	Dimensioni Dimensions [mm]	Omologazione Homologation		
						Classe Class	ECE R55	Tipo Type
FDHG001 FDHB001	167 - 267	18	120	341	1205 x 1000	S	E20 01-2741	FDH
FDHG002 FDHB002	167 - 317	18	120	344	1205 x 1000	S	E20 01-2741	FDH
FDHG003 FDHB003	167 - 367	18	120	346	1205 x 1000	S	E20 01-2741	FDH

La versione standard non prevede fori per fissaggio al telaio  
The standard version is not drilled

Posizione alta  
High position

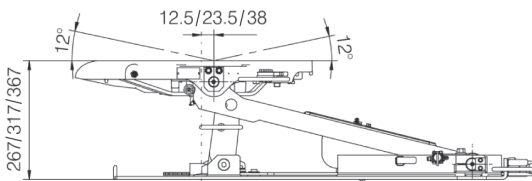

Posizione bassa  
Low position

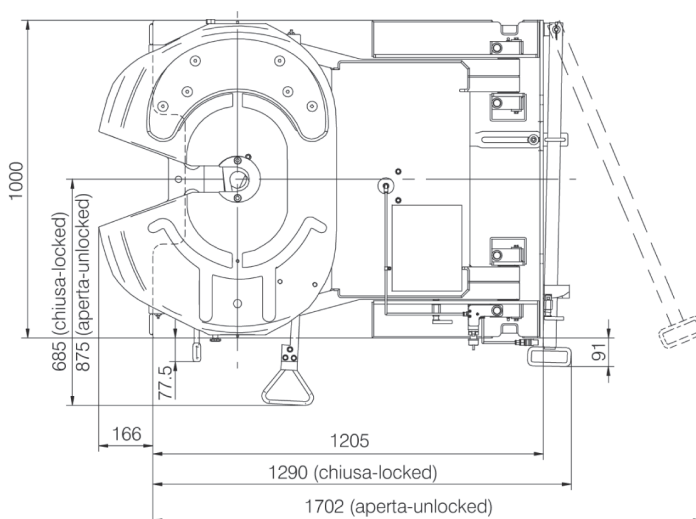
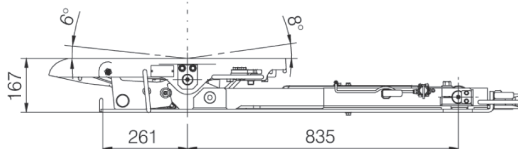

**Crea il tuo codice:**

**Create your part number:**

**FDH X XX X**

Ralla doppia altezza  
Height-adjustable Fifth  
wheel

Versione piatto ralla  
Plate version

Tipo di foratura - Type of drilling

Altezza - Height - H

**Versione piatto ralla - Plate version**

G = Ralla con lubrificazione standard  
Standard greasing plate

B = Piatto autolubrificante - Low lube

**Tipo di foratura - Type of drilling**

00 = standard (non forata - not drilled)

01 = Daimler

02 = Iveco

03 = Scania

04 = Volvo

05 = Man

06 = Renault

07 = Daf

08 = Mercedes new Actros

**Altezza - Height - H**

1 = 267

2 = 317

3 = 367

# FDH Ricambi - Spare parts



SAF-HOLLAND Group

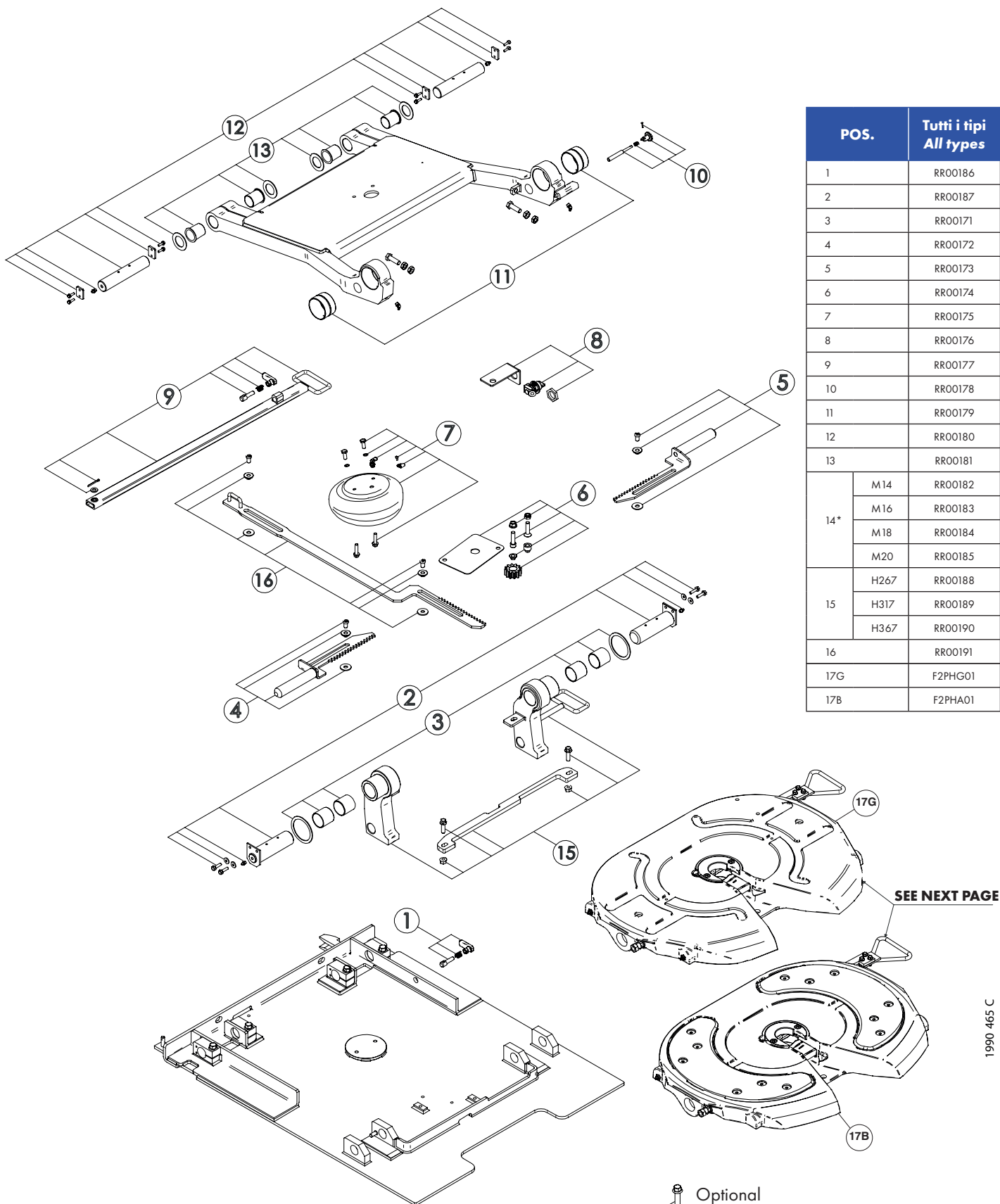

POS.	Tutti i tipi All types	
1		RR00186
2		RR00187
3		RR00171
4		RR00172
5		RR00173
6		RR00174
7		RR00175
8		RR00176
9		RR00177
10		RR00178
11		RR00179
12		RR00180
13		RR00181
14*	M14	RR00182
	M16	RR00183
	M18	RR00184
	M20	RR00185
15	H267	RR00188
	H317	RR00189
	H367	RR00190
16		RR00191
17G		F2PHG01
17B		F2PHA01

SEE NEXT PAGE

1990 465 C

POS.	Tipo Type	Kit Viti Screws kit
14*	VOLVO	RR00182
	IVECO - MAN - RENAULT - DAF	RR00183
	SCANIA	RR00184
	DC - MERCEDES	RR00185

- 14
- Optional
  - Kit viti di fissaggio al telaio
  - Frame fixing screws kit
  - Kit Befestigungsschrauben für fahrzeugrahmen
  - Kit de vis de fixation au châssis

## FDH Ricambi - Spare parts

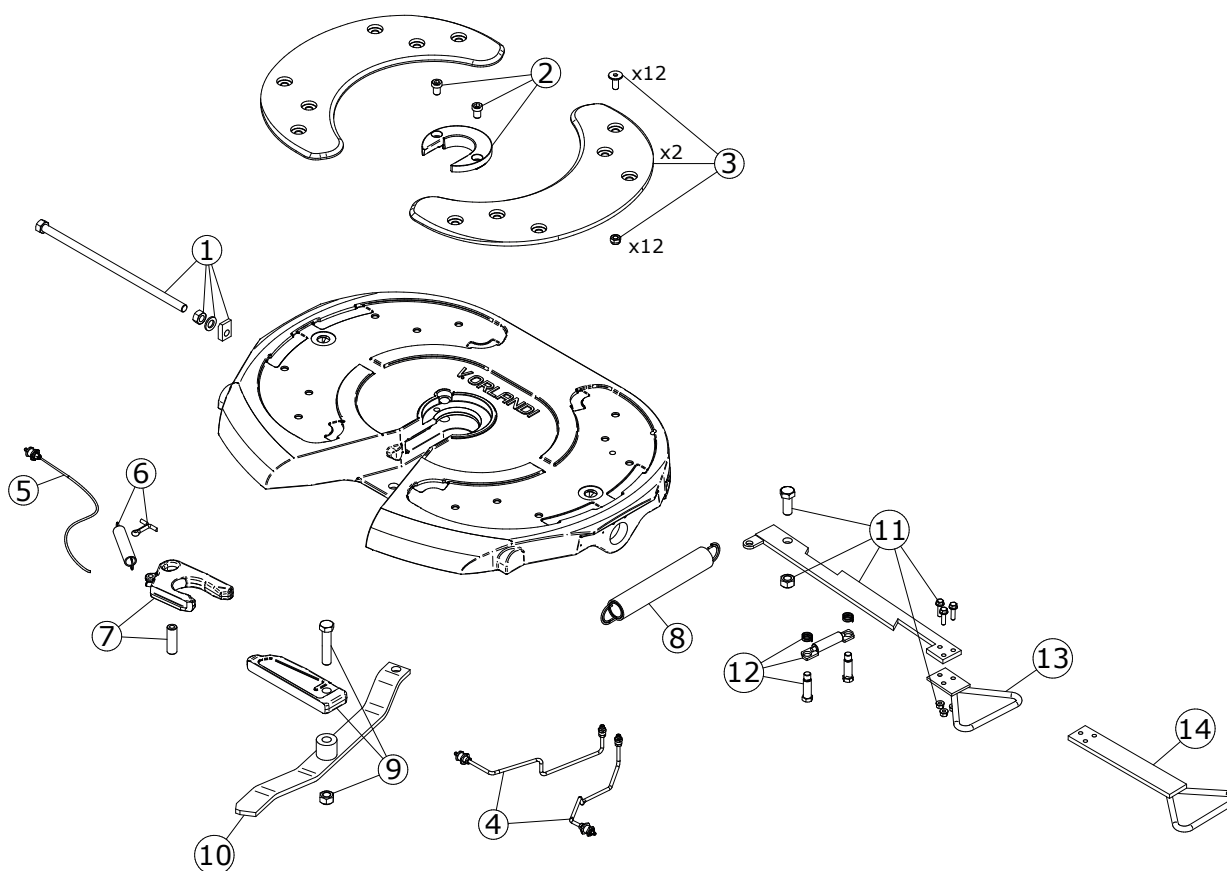

POS.	Low Lube	Grease
1	RR00054	RR00054
2	RR00055	RR00055
3	RR00279	-
4	-	RR00056
5	RR00057	RR00057
6	RR00058	RR00058
7	RR00059	RR00059
8	RR00037	RR00037
9	RR00060	RR00060
10	RR00061	RR00061
11	RR00078	RR00078
12	RR00048	RR00048
13	RR00079	RR00079
14	RR00083	RR00083





1

2

5

6

8

8a

9

6

7

17

14

15

13

10

11

19

16

12

21b

21a

42.5 42.5

415

339

85 45

271

406

30

20

19

880

695

510

V. ORLANDI

668 (LOCKED)

840 (UNLOCKED)

10-35

287 +10

95

42.5 42.5

303

207 ±5

129

250

140 +10

V. ORLANDI

360

210

5° 5°

90

360°

281

85

S I S T E M I

VORLANDI  
DI TRAINING

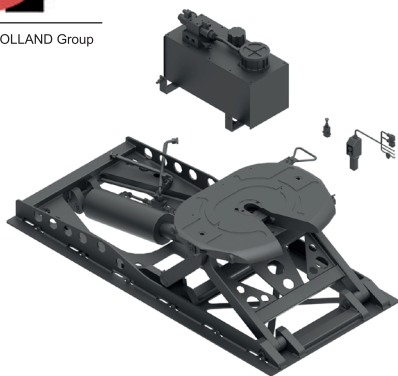

# FPX

Ralla sollevatrice  
Lifting Fifth wheel

<b>2"</b>	Omologazione Homologation	-
-----------	------------------------------	---

## Dati tecnici - Technical data

Codice Part number	Carico sollevabile Lifting capacity [t]	Peso Weight [kg]	Larghezza del telaio Width of chassis [mm]	Dimensioni Dimensions [mm]	Omologazione Homologation
F2PXG00	22	658	780 - 930	2130x1030	-
F2PXB00	22	658	780 - 930	2130x1030	-

ATTENZIONE: solo per uso privato!  
ATTENTION: private area use only!

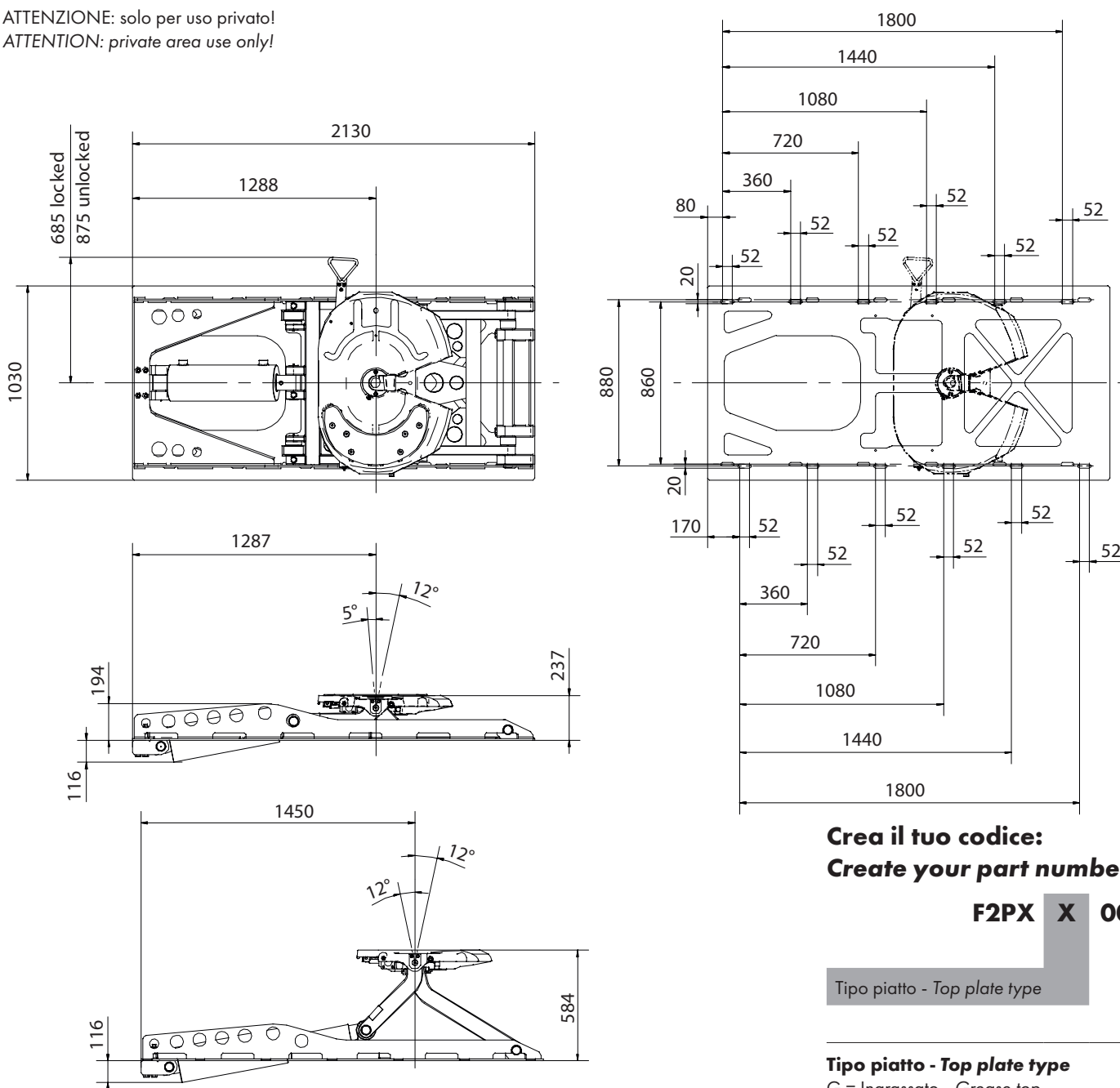

**Crea il tuo codice:**  
**Create your part number:**

**F2PX X 00**

Tipo piatto - Top plate type

**Tipo piatto - Top plate type**

G = Ingrassato - Grease top

B = Piatto autolubrificante - Low lube

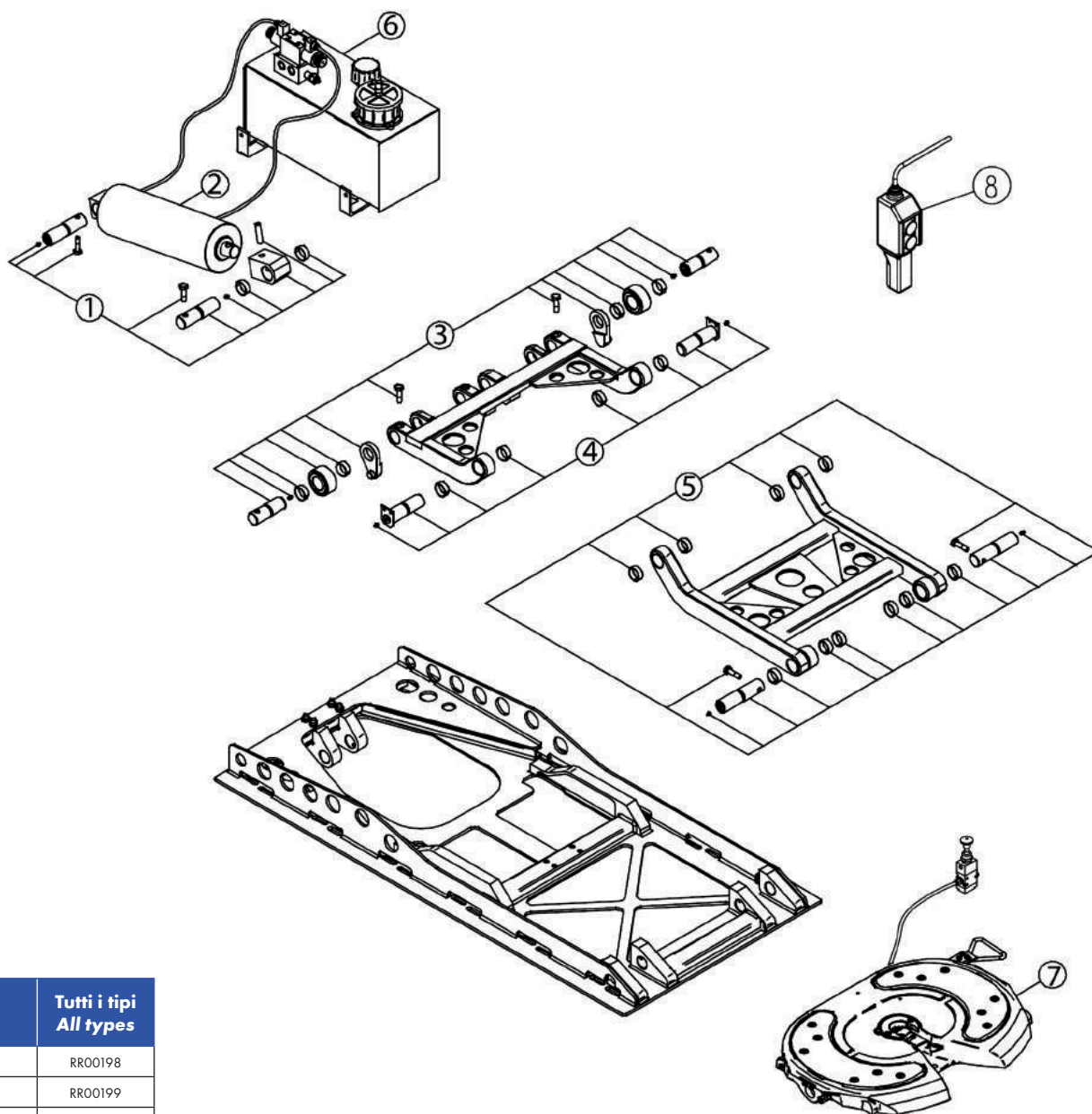

POS.	Tutti i tipi All types
1	RR00198
2	RR00199
3	RR00200
4	RR00201
5	RR00202
6	RR00203
7	F2PXCOP
8	RR00250

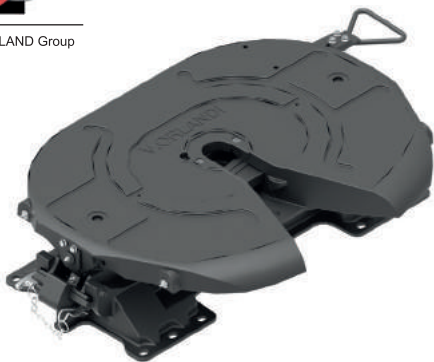

# RP10 - K

Ralla compensata  
Compensated Fifth wheel - bolt on

2"

Omologazione  
Homologation

ECE R55

## Dati tecnici - Technical data

Codice Part number	Altezza H H-Height [mm]	Valore D D-Value [kN]	Carico verticale U Imposed load [t]	Peso Weight [kg]	Omologazione Homologation		
					Classe Class	ECE R55	Tipo Type
F2K1G40	250	152	20	239	G50-X	E11 01-10049	F2K
F2K1B40	250	152	20	239	G50-X	E11 01-10049	F2K

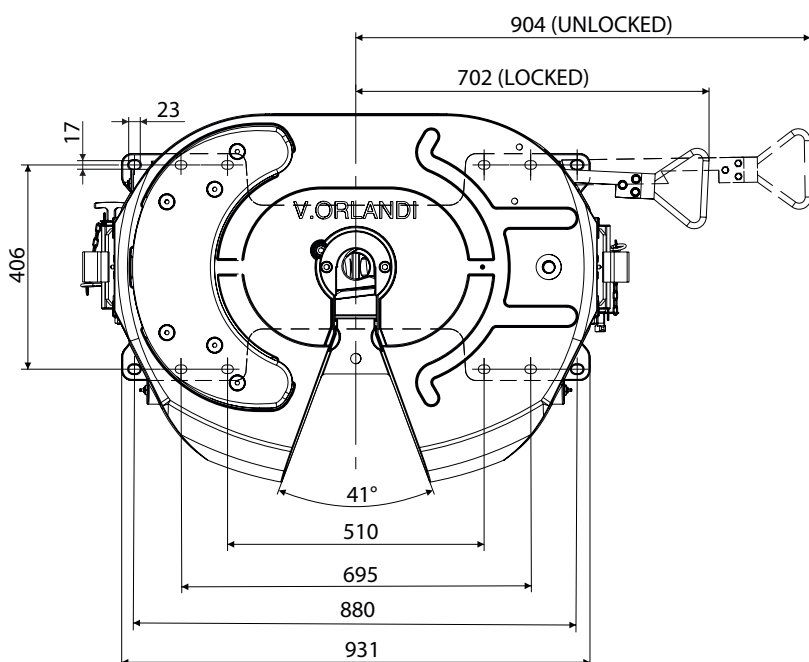
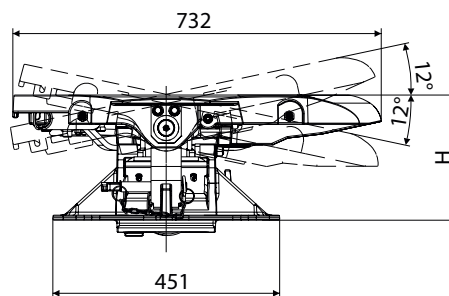
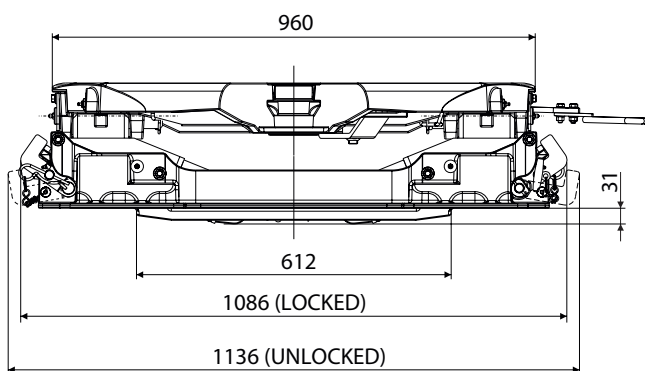
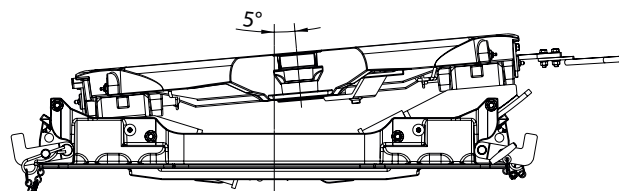
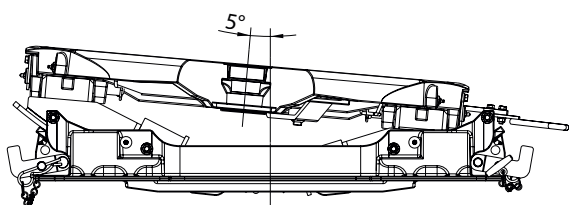

**Crea il tuo codice:**  
**Create your part number:**

**F2K1 X 40**

Tipo piatto - Top plate type

**Tipo piatto - Top plate type**

G = Ingrassato - Grease top

B = Piatto autolubrificante - Low lube



## RP10 - K Ricambi - Spare parts

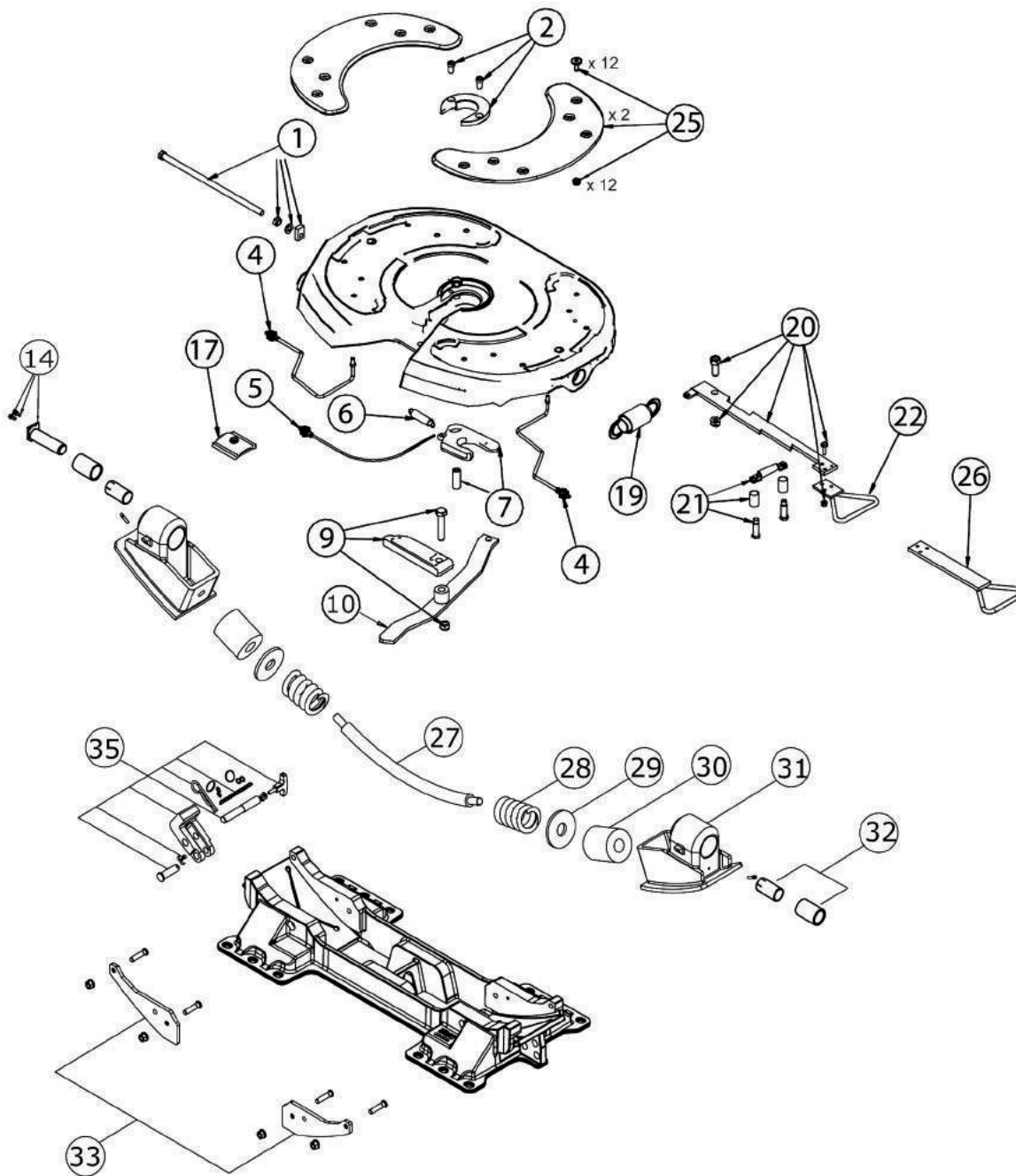



POS.	Tutti i tipi All types	POS.	Tutti i tipi All types
1	RR00222	22	RR00079
2	RR00055	25	RR00279
4	RR00056	26	RR00083
5	RR00057	27	RR00216
6	RR00058	28 (x2)	RR00217
7	RR00059	29 (x2)	RR00218
9	RR00060	30 (x2)	RR00219
14	RR00280	31 (x2)	RR00220
17	RR00065	32 (x 2+2)	RR000221
19	RR00037	33	RR00223
20	RR00078	35	RR00245
21	RR00048		

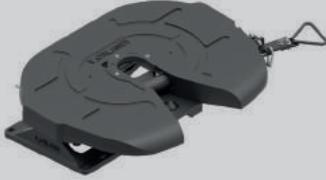

# Ralle 3,5" - Fifth wheels 3,5"

## INDICE - INDEX

Serie Series	Perni di articolazione Kingpins	Omologazione Homologation	Descrizione Description	Pagina Page
RP90 / RP59 	3,5" - 2"	ECE R55	Ralla su tamponi Fifth wheel on rubber mounting - bolt on	20
RP90-DO / RP59-DO 	3,5" - 2"	ECE R55	Ralla doppia oscillazione Double oscillating fifth wheel bolt on	22
RP100-DO / RP95-DO 	4" - 3,5"	ECE R55	Ralla doppia oscillazione Double oscillating fifth wheel bolt on	24



# RP90 / RP59

Ralla su tamponi  
Fifth wheel on rubber mounting - bolt on

**3,5" / 2"**

Omologazione  
Homologation

ECE R55

## Dati tecnici - Technical data

Codice Part number	Perno di Articolazione Kingpins	Altezza H H-Height [mm]	A	B	Valore D D-Value [kN]	Carico verticale U Imposed load [t]	Peso Weight [kg]	Omologazione Homologation		
								Classe Class	ECE R55	Tipo Type
F3T1G40	3,5"	190	12°	15°	260	40	200	S	E20 01-2568	RP90
F3T1G50	3,5"	250	15°	15°	260	40	215	S	E20 01-2568	RP90
F2T3G40	2"	190	12°	15°	170	24	200	G50-X	E20 01-2688	RP59
F2T3G50	2"	250	15°	15°	170	24	215	G50-X	E20 01-2688	RP59

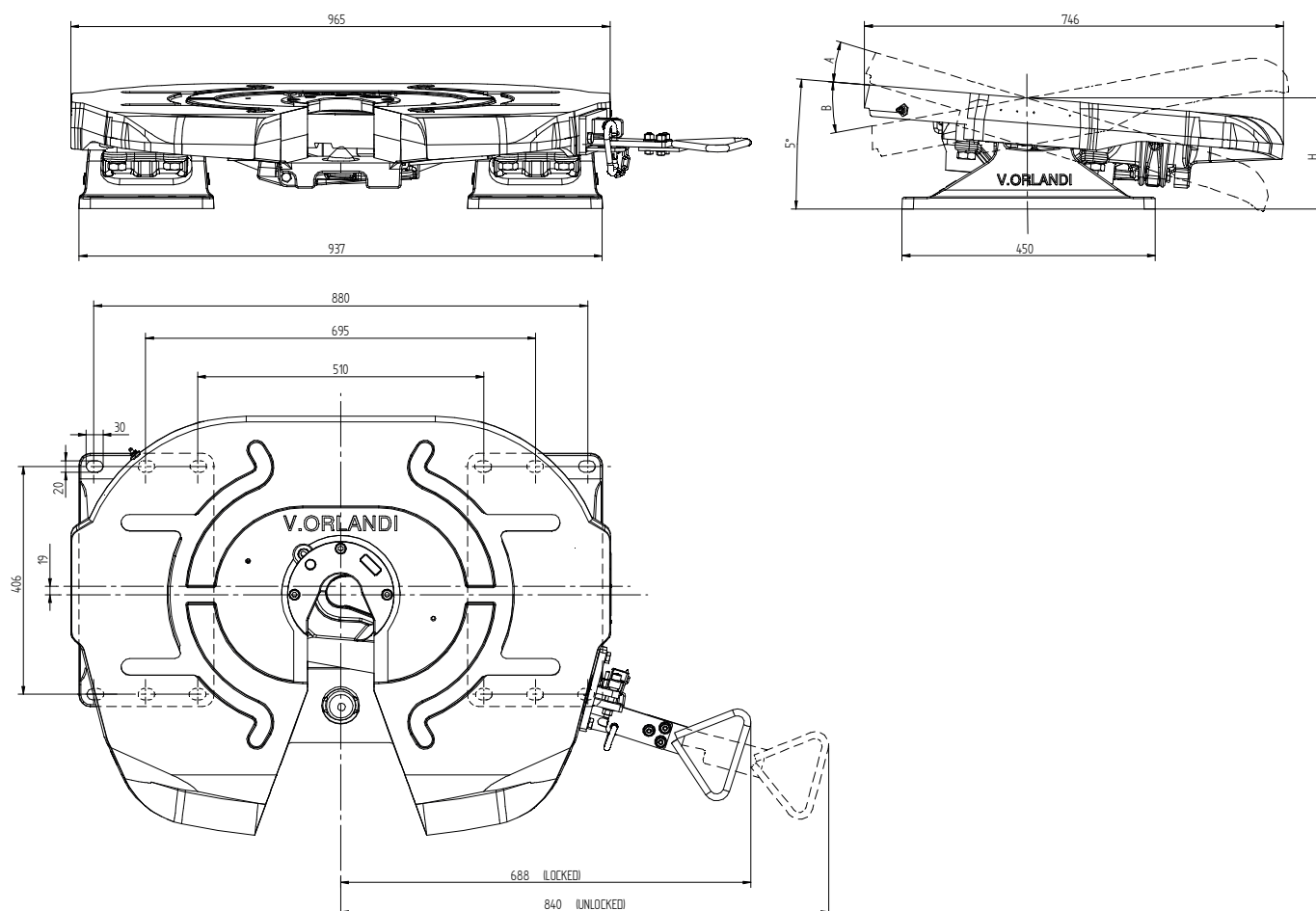



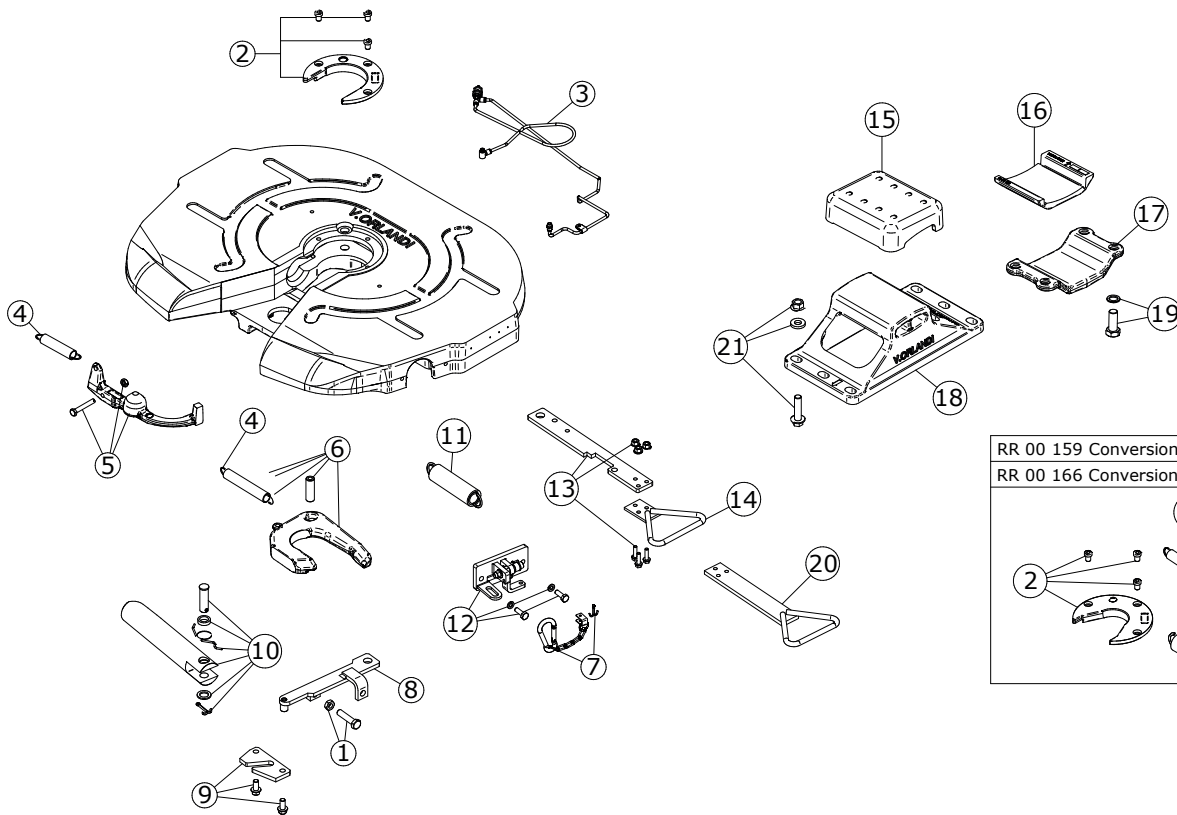

RR 00 159 Conversion kit from 2" to 3.5"  
RR 00 166 Conversion kit from 3.5" to 2"

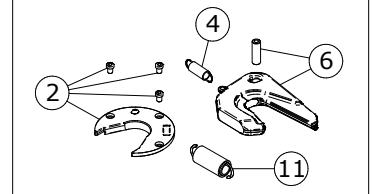

POS.	Tutti i tipi All types	Codice - Part number			
		F3T1G40	F3T1G50	F2T3G40	F2T3G50
1	RR00143				
2		RR00126	RR00126	RR00164	RR00164
3	RR00127				
4	RR00129				
5	RR00131				
6		RR00147	RR00147	RR00290	RR00290
7	RR00227				
8	RR00141				
9	RR00142				
10	RR00138				
11	RR00140				
12	RR00135				
13	RR00149				
14	RR00079				
15	RR00154				
16	RR00155				
17	RR00156				
18		RR00152	RR00153	RR00152	RR00153
19	RR00157				
20	RR00083				
<b>KIT</b>					
2, 4, 6		RR00162	RR00162	RR00168	RR00168
(15, 16, 19) x2	RR00161				
21	RR00050				

# RP90 - DO / RP59 - DO

Ralla doppia oscillazione  
Double oscillating fifth wheel bolt on



## 3,5" / 2"

Omologazione  
Homologation

ECE R55

### Dati tecnici - Technical data

Codice Part number	Perno di Articolazione Kingpins	Altezza H H-Height [mm]	Valore D D-Value [kN]	Carico verticale U Imposed load [t]	Peso Weight [kg]	Omologazione Homologation		
						Classe Class	ECE R55	Tipo Type
F3C1G60	3,5"	290	260	40	306	S	E20 01-2568	RP90
F2C1G60	2"	290	170	24	306	G50-X	E20 01-2688	RP59

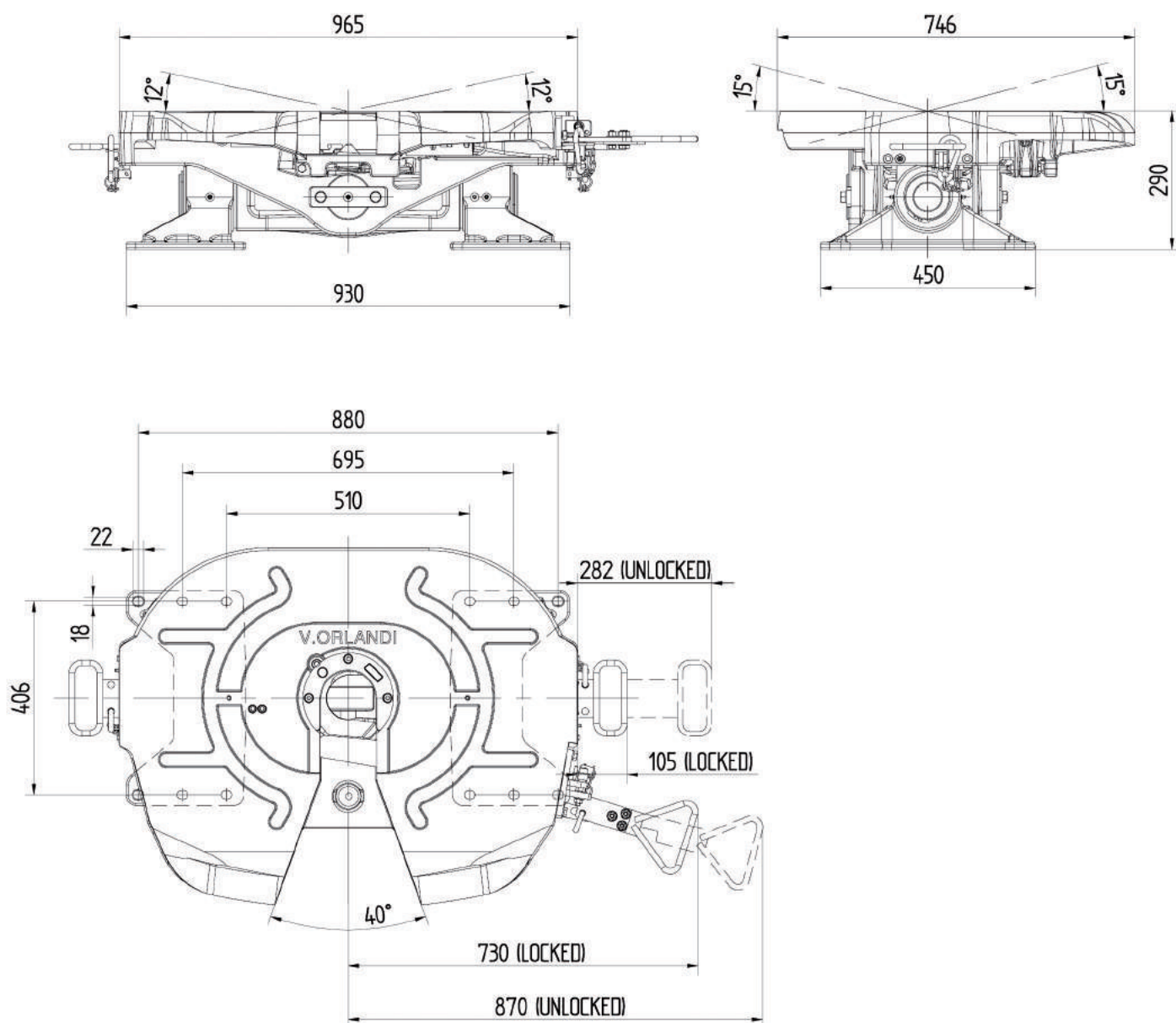

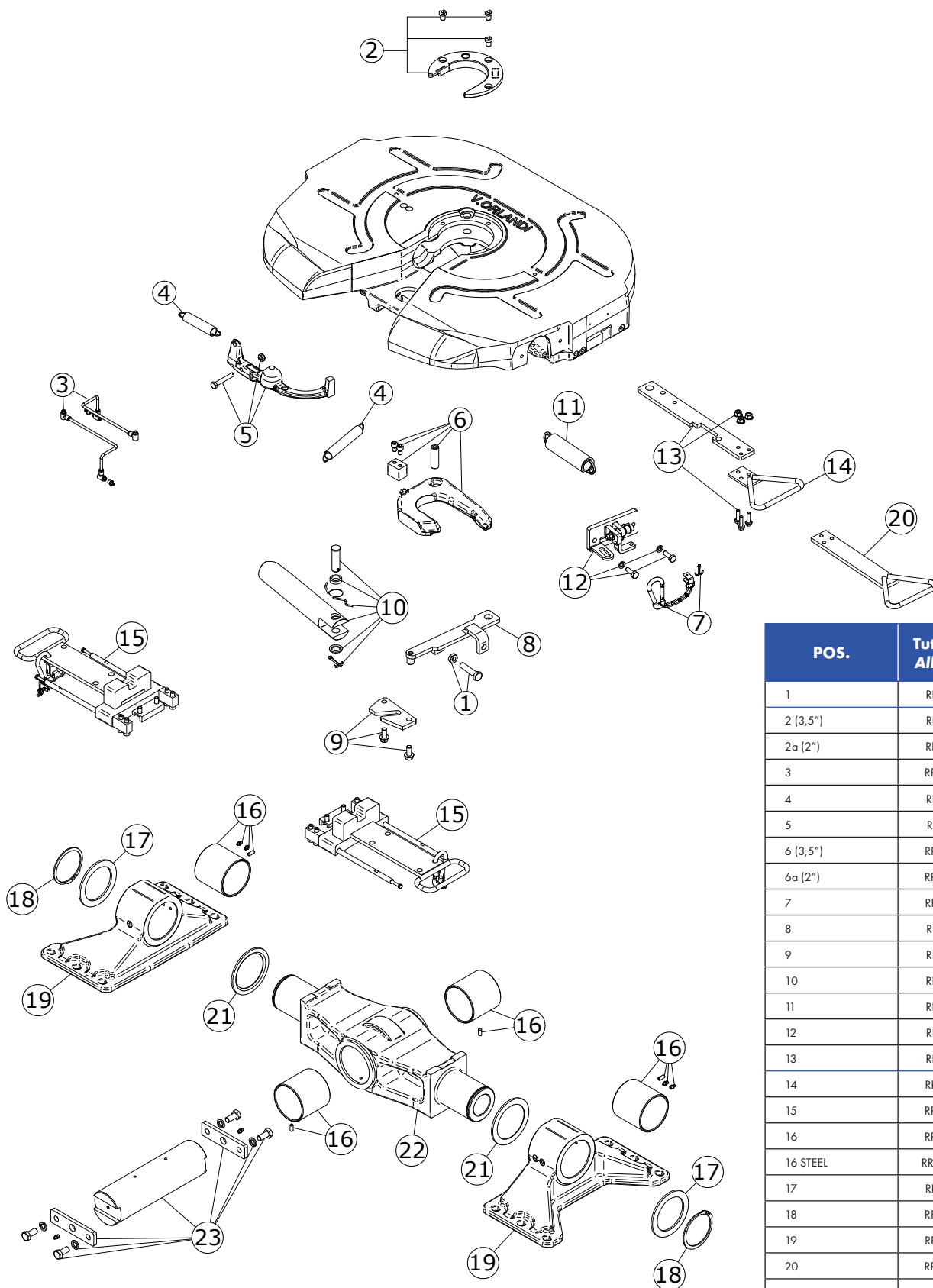

POS.	Tutti i tipi All types
1	RR00143
2 (3,5")	RR00126
2a (2")	RR00164
3	RR00283
4	RR00129
5	RR00131
6 (3,5")	RR00289
6a (2")	RR00290
7	RR00227
8	RR00141
9	RR00142
10	RR00138
11	RR00140
12	RR00135
13	RR00149
14	RR00079
15	RR00288
16	RR00238
16 STEEL	RR00238S
17	RR00241
18	RR00240
19	RR00239
20	RR00083
21	RR00242
22	RR00244
23	RR00243
<b>KIT 2"</b>	
2a, 6a, 4, 11	<b>RR00166</b>
2a, 6a	RR00168
<b>KIT 3,5"</b>	
2, 5, 4, 11	<b>RR00159</b>
2, 6	RR00162

# RP100 - DO / RP95 - DO

Ralla doppia oscillazione  
Double oscillating Fifth wheel bolt on

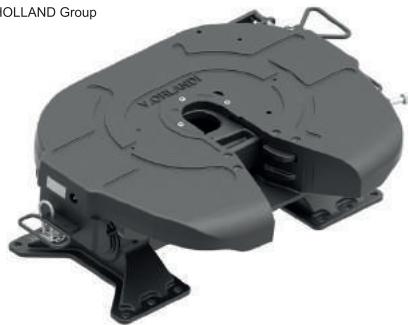

## 4" / 3,5"

Omologazione  
Homologation

ECE R55

### Technical data

Codice Part number	Perno di Articolazione Kingpins	Altezza H H-Height [mm]	Valore D D-Value [kN]	Carico verticale U Imposed load [t]	Peso Weight [kg]	Omologazione Homologation		
						Classe Class	ECE-01 R55-01	Tipo Type
F4C1G70	4"	350	260	40	362	S	E20 01-3492	RP100
F3C1G70	3,5"	350	260	40	362	S	E20 01-3511	RP95

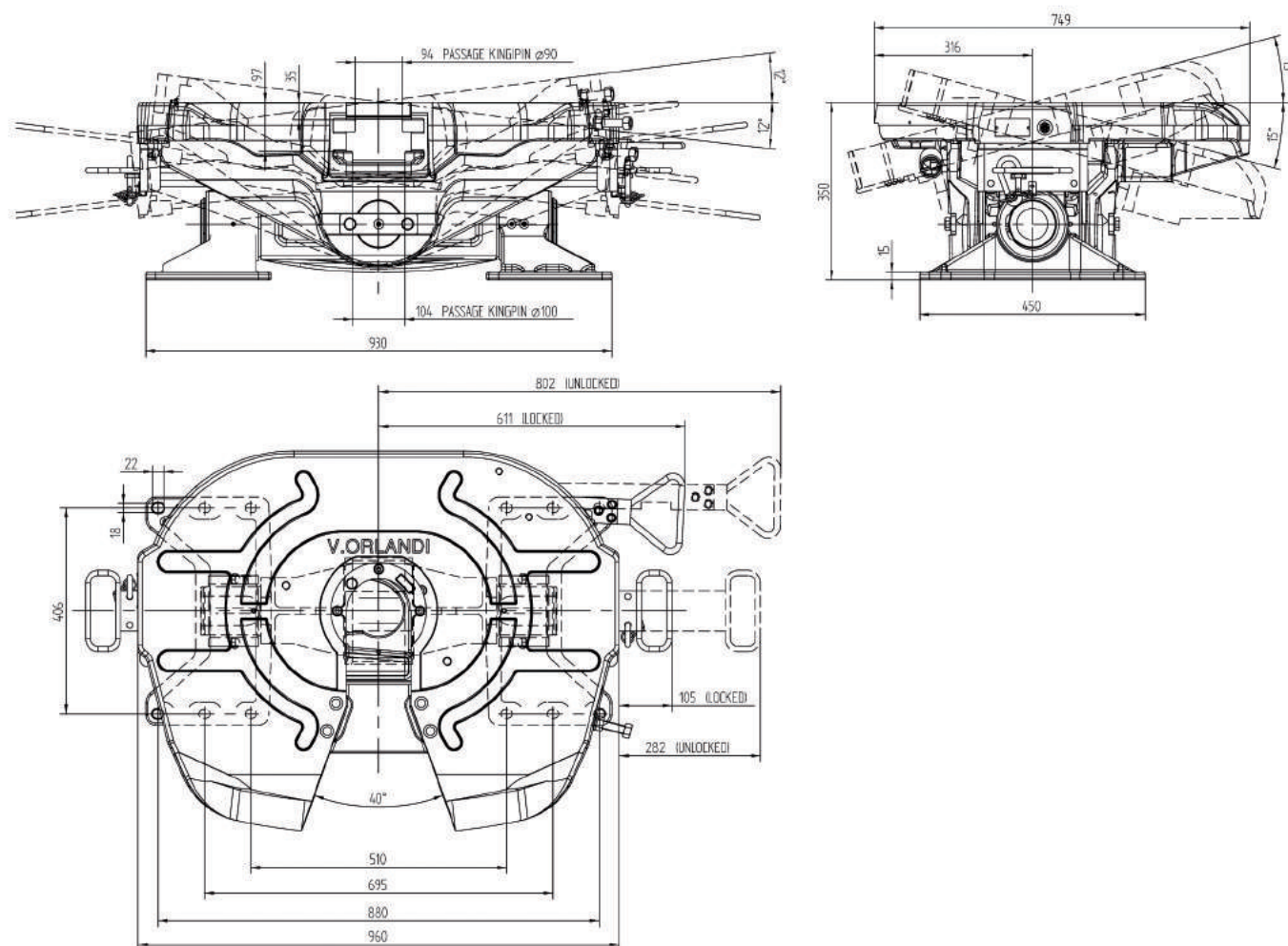

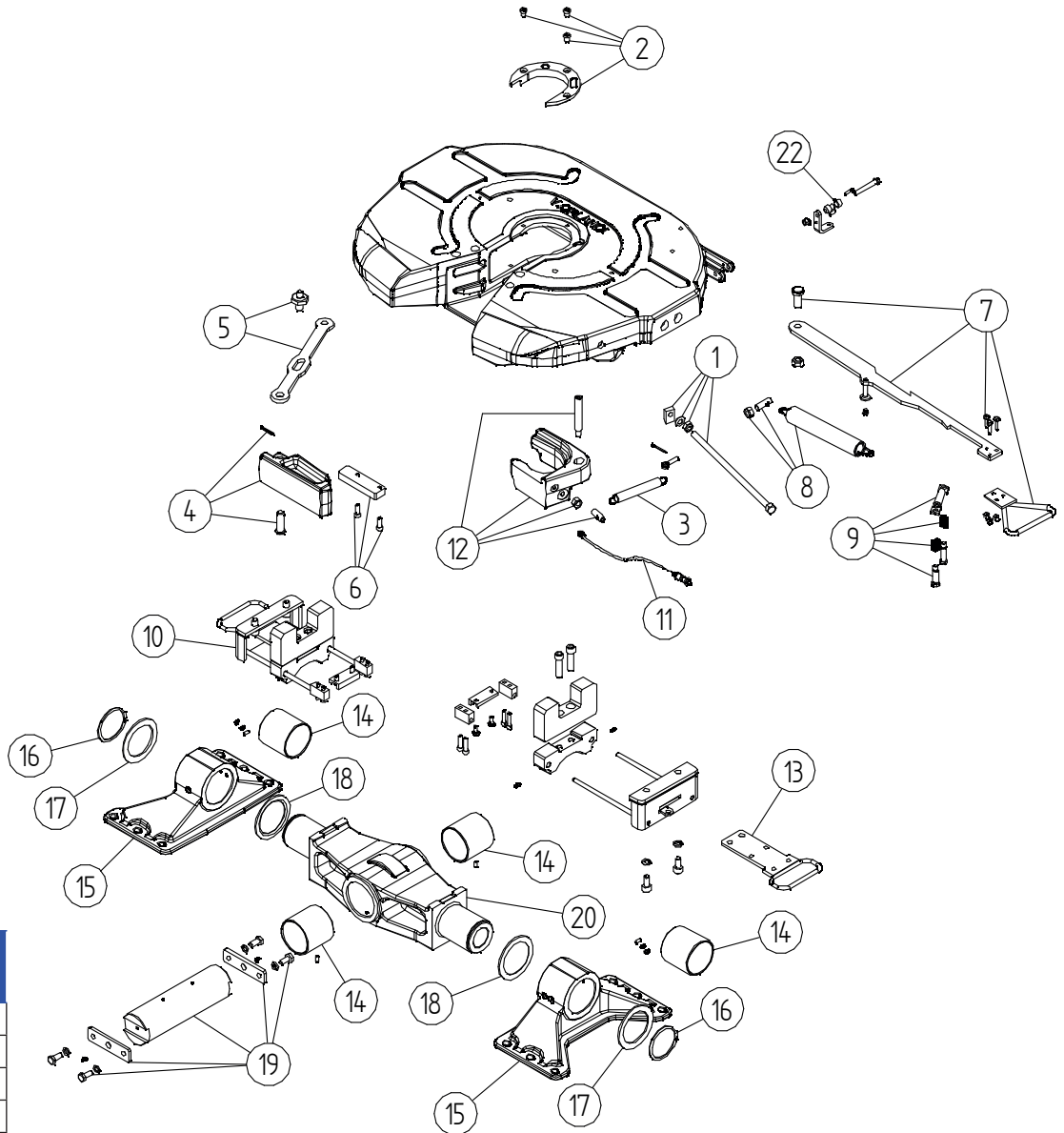

POS.	Tutti i tipi All types
1	RR00054
2a (3,5")	RR00247
2b (4")	RR00226
3	RR00058
4a (3,5")	RR00248
4b (4")	RR00228
5	RR00229
6	RR00230
7	RR00231
8	RR00232
9	RR00048
10	RR00234
11	RR00235
12a	RR00249
12b	RR00236
13	RR00237
14	RR00238
15	RR00239
16	RR00240
17	RR00241
18	RR00242
19	RR00243
20	RR00244
21 (3,5")	RR00253
22	RR00263

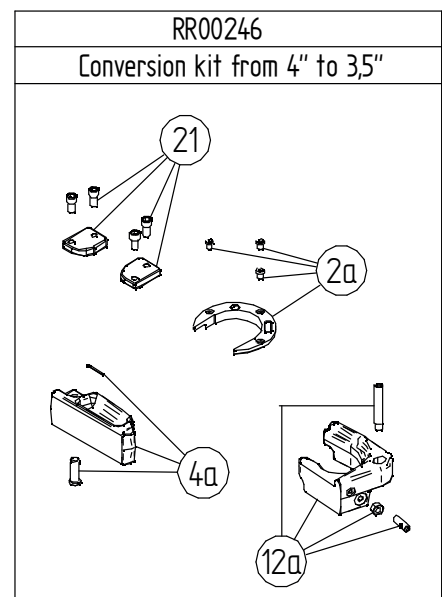





# Accessori - Accessories

## INDICE - INDEX

Serie Series	Descrizione Description	Pagina Page
	Piastre di avanzamento ralla Fifth wheel slider	28
	Ralle a sfera Ball races	32
	Perni di articolazione Kingpins	34
	Sollevatori telescopici Landing gear	36

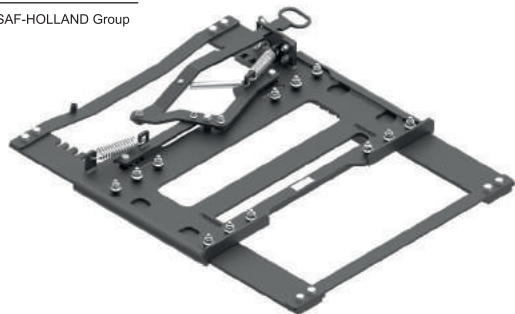

# FSL

Piastre di avanzamento ralla  
Fifth wheel slider

2"

Omologazione  
Homologation

ECE R55

## Dati tecnici - Technical data

Codice Part number	Valore D D-Value [kN]	Carico verticale U Imposed load [t]	Corsa Stroke [mm]	Peso Weight [kg]	Larghezza montaggio Fitting width [mm]	Dimensioni Dimensions [mm]	Omologazione Homologation		
							Classe Class	ECE R55	Tipo Type
FSL0000 (solo - only RS08)	152	20	525	120	780 - 900	1250 x 960	J	E11 01-10054	FSL
FSL1000	152	20	525	126	930	1250 x 1060	J	E11 01-10054	FSL

La versione standard non prevede fori per fissaggio al telaio - The standard version is not drilled

**Crea il tuo codice:**  
**Create your part number:**

**FSL X XX X**

Larghezza telaio - Width of chassis

Tipo foratura - Type of drilling

Tipo di apertura - Type of opening

**Larghezza telaio - Width of Chassis**

0 = 780 - 900

1 = 930

**Tipo foratura - Type of drilling**

00 = standard (non forata - not drilled)

01 = Dailmer

02 = Iveco

03 = Scania

04 = Volvo

05 = Man

06 = Renault

07 = Daf

08 = Mercedes new Actros

**Tipo di apertura - Type of opening**

0 = Manuale - Manual

1 = kit pneumatico - pneumatic remote kit

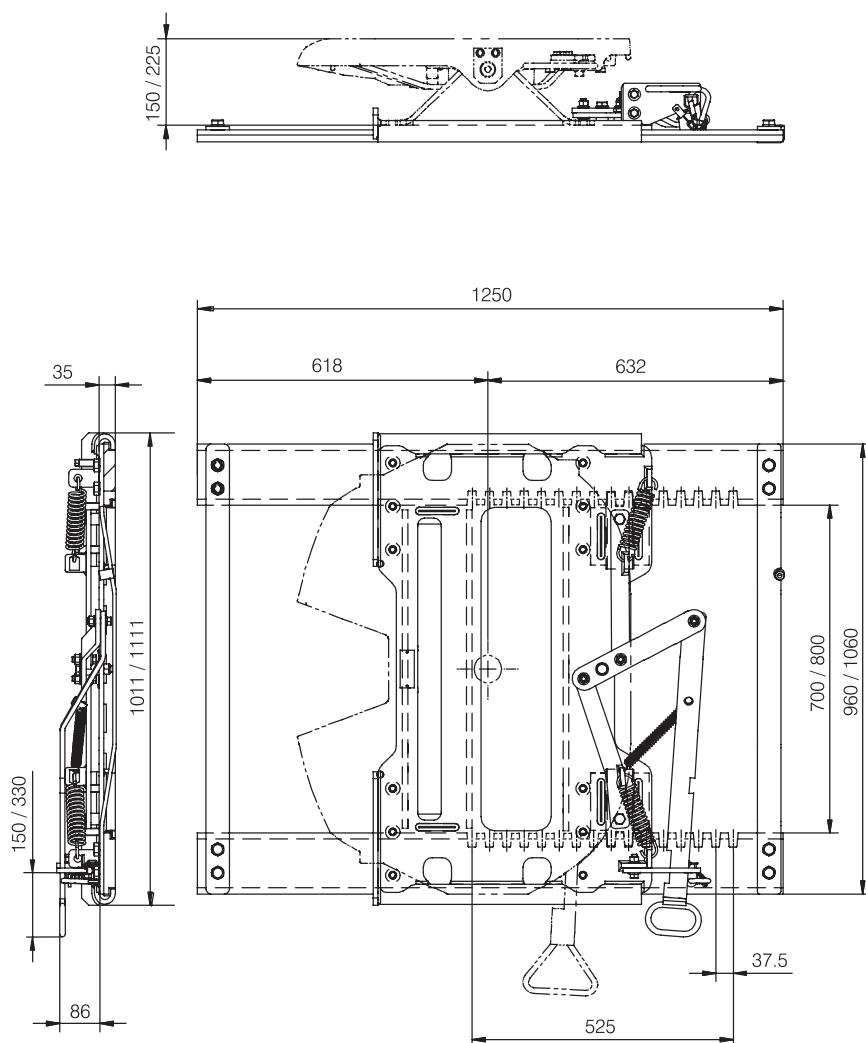



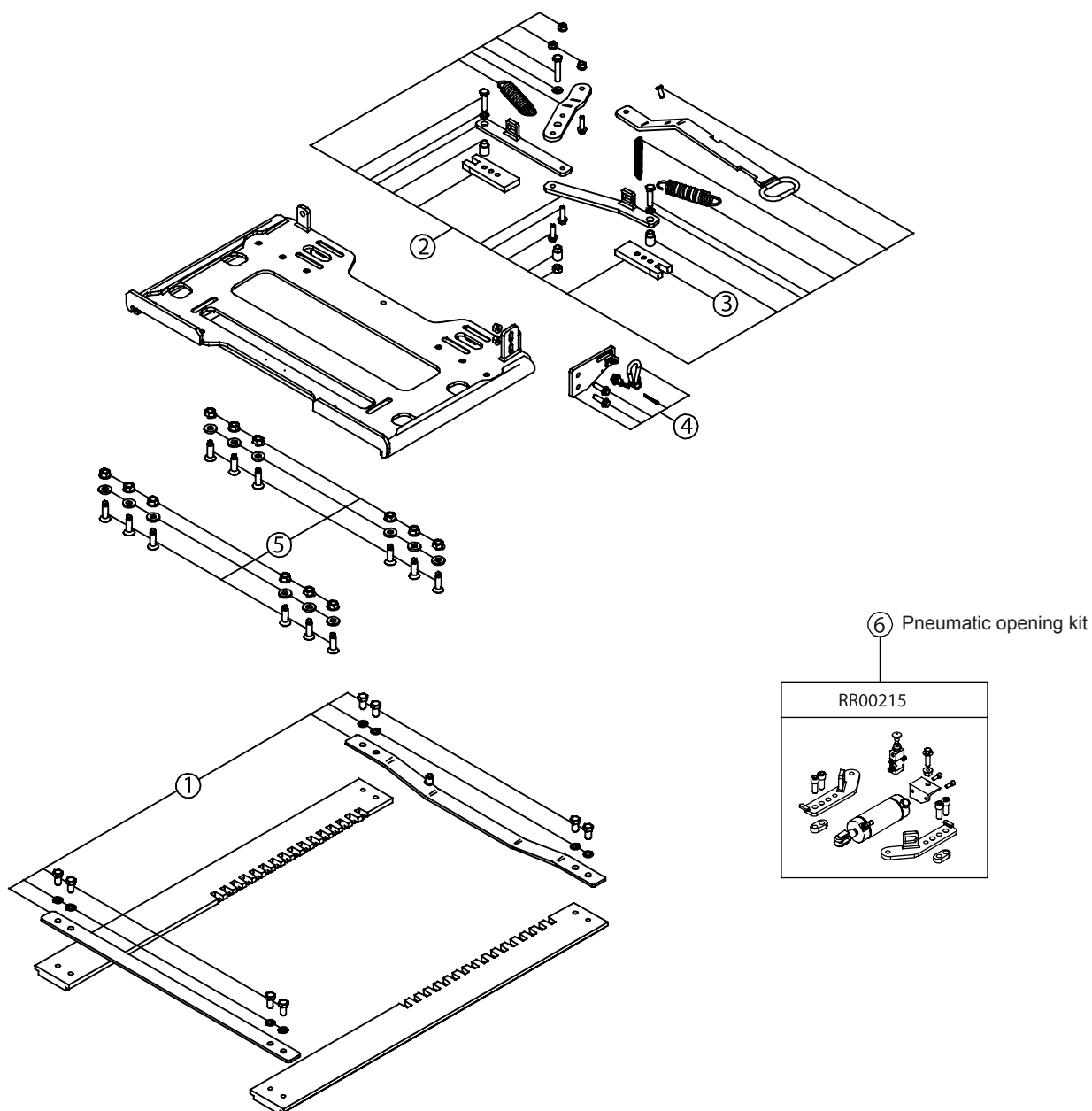

POS.	Tutti i tipi All types	FSL0000	FSL1000
1		RR00204	RR00205
2	RR00206		
3	RR00207		
4	RR00208		
5	RR00209		
6	RR00215		

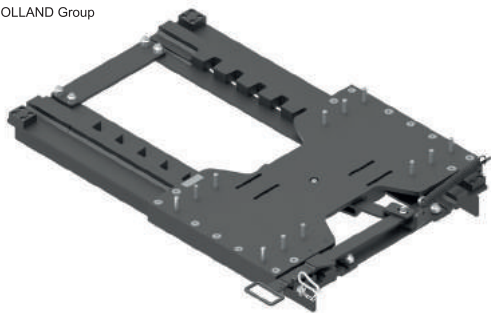

# SHD

Piastre di avanzamento ralla serie pesante  
Slider HHD Heavy Duty

2" / 3,5"

Omologazione  
Homologation

ECE R55

## Dati tecnici - Technical data

Codice Part number	Valore D D-Value [kN]	Carico Verticale U Vertical load U [t]	Peso Weight [kg]	Larghezza telaio Width of chassis [mm]	Omologazione Homologation		
					Classe Class	ECE R55	Tipo Type
SHD0000	260	40	349	756 - 810	J	E11 01-11068	SHD
SHD1000	260	40	313	840 - 865	J	E11 01-11068	SHD

**Crea il tuo codice:**  
**Create your part number:**

SHD X X X X

Larghezza telaio - Width of chassis

Rinforzo telaio - Chassis reinforcement

Tipo di apertura - Type of opening

Lunghezza slider - Slider length

### Larghezza telaio - Chassis width

0 = Stretto - Narrow 756 - 810

1 = Largo - Wide 840 - 865

### Rinforzo telaio - Chassis reinforcement

0 = Incluso - Included

1 = Non incluso - Not included

### Tipo di apertura - Type of opening

0 = Manuale - Manual

1 = Pneumatico - Pneumatic

### Lunghezza slider - Slider length (pitch 105 mm)

Total length (L) Travel length (H)

0 = 1400	630
1 = 1610	840
L = 1820	1050
2 = 2030	1260
3 = 2240	1470
4 = 2450	1680
5 = 2660	1980
6 = 2810	2100
7 = 2975	2205
8 = 3185	2415

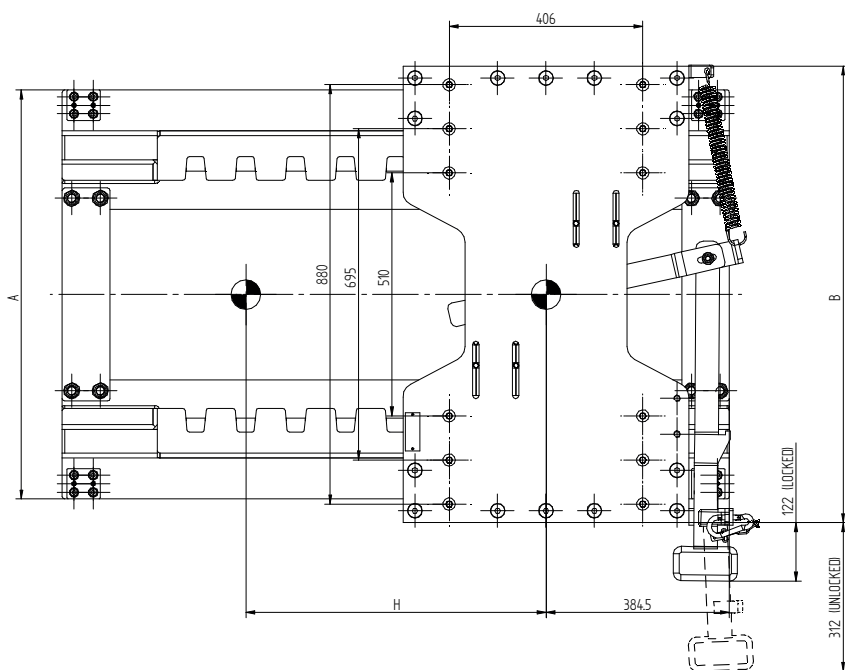
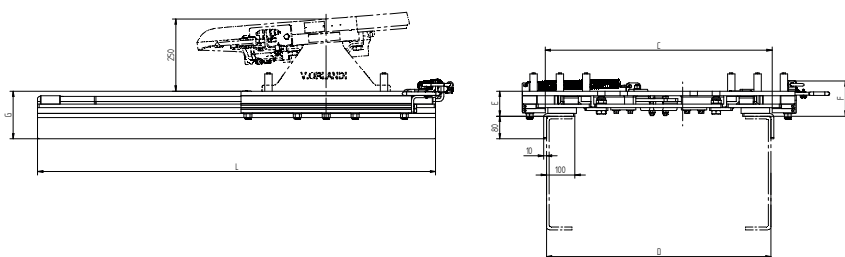

Codice Part number	A mm	B mm	C mm	D mm	E mm	F mm	G mm
SHD0000	858	958	798	756 - 810	88	124	168
SHD1000	954	1054	894	840 - 865	68	104	148

## SHD Ricambi - Spare parts



SAF-HOLLAND Group

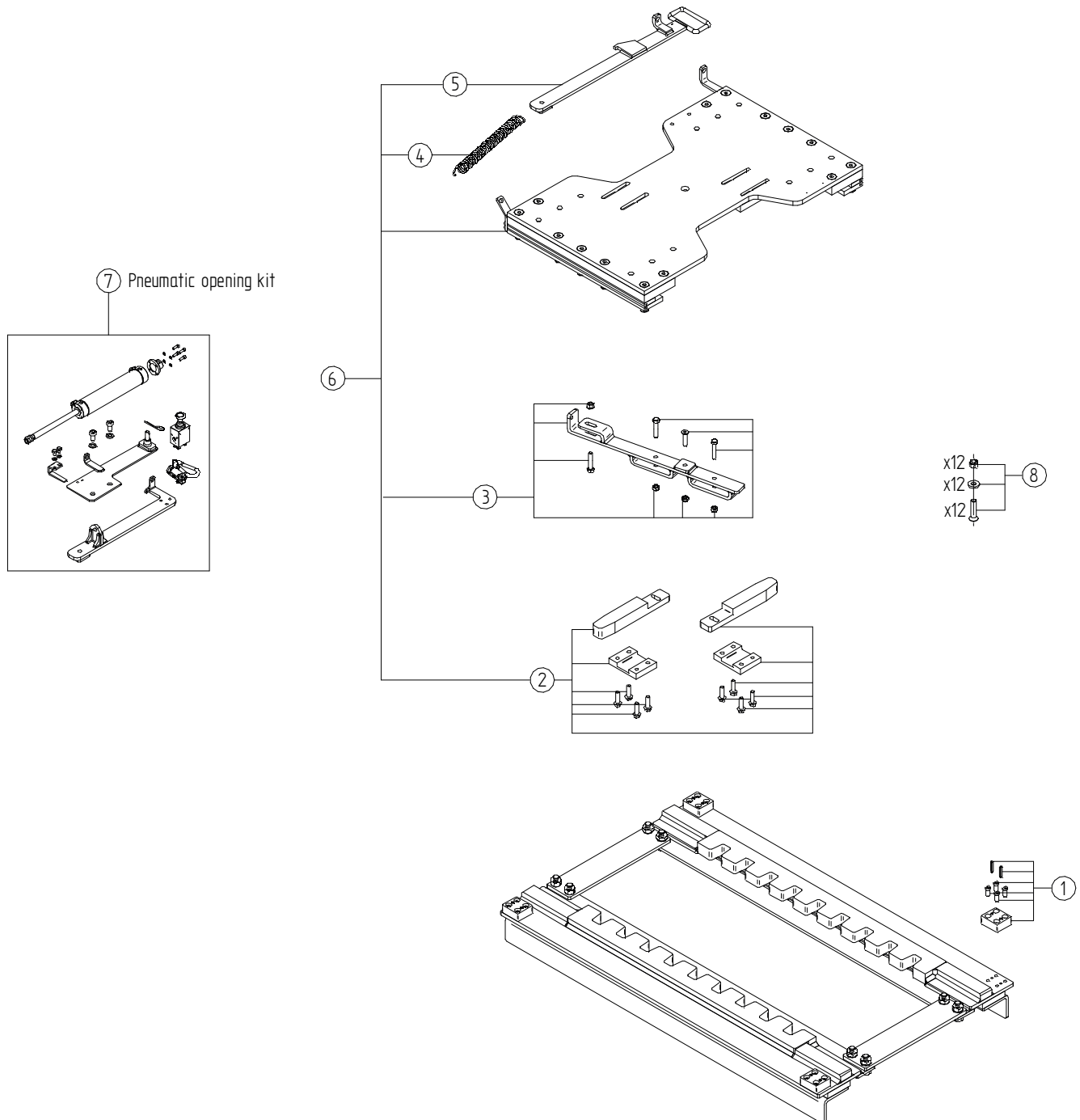

POS.	Tutti i tipi All types	SHD0000	SHD1000	SHD0010	SHD1010
1	RR00303				
2		RR00304	RR00305	RR00304	RR00305
3	RR00306				
4	RR00307				
5		RR00308	RR00309	RR00310	RR00310
6		RR00330	RR00329	RR00324	RR00328
7				RR00315	RR00300
8	RR00302				



# BW

Ralle a sfera singola  
Single-row ball race

## Dati tecnici - Technical data

Codice Part number	Foratura Drilling [mm]	Carico assiale Axial load [kN]	A [mm]	B [mm]	C [mm]	D [mm]	E [mm]	F [mm]	d [mm]	h [mm]	H [mm]	Peso Weight [kg]
BW08100	-	80	1000	-	881	853	-	1008	-	9	90	64
BW10100	-	100	1000	-	881	853	-	1008	-	9	90	64
BW10111	1	100	1100	1060	981	953	1074	1108	18	9	90	71
BW12111	1	120	1100	1060	981	953	1074	1108	18	9	90	71
BW13121	1	130	1200	1160	1081	1053	1174	1208	18	9	90	78
BW14131	1	140	1300	1260	1181	1153	1274	1308	18	9	90	84
BW14130	-	140	1300	-	1181	1153	-	1308	-	9	90	84
BW16111	1	160	1100	1060	981	953	1074	1108	18	9	90	70

### FORATURA 1 - HOLE PATTERN 1

Anello inferiore - Lower ring - Unterer Ring  
Anneau inférieur - Нижнее кольцо

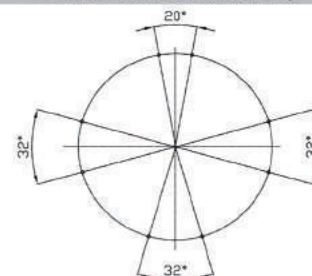

DIREZIONE DI MARCIA - DIRECTION OF TRAVEL  
FAHRTRICHTUNG - SENS DE LA MARCHÉ  
НАПРАВЛЕНИЕ ДВИЖЕНИЯ

Anello superiore - Upper ring - Oberer Ring  
Anneau supérieur - Верхнее кольцо

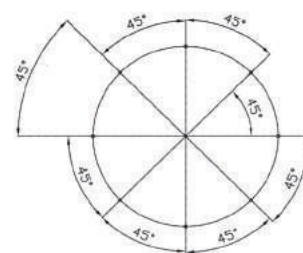

DIREZIONE DI MARCIA - DIRECTION OF TRAVEL  
FAHRTRICHTUNG - SENS DE LA MARCHÉ  
НАПРАВЛЕНИЕ ДВИЖЕНИЯ

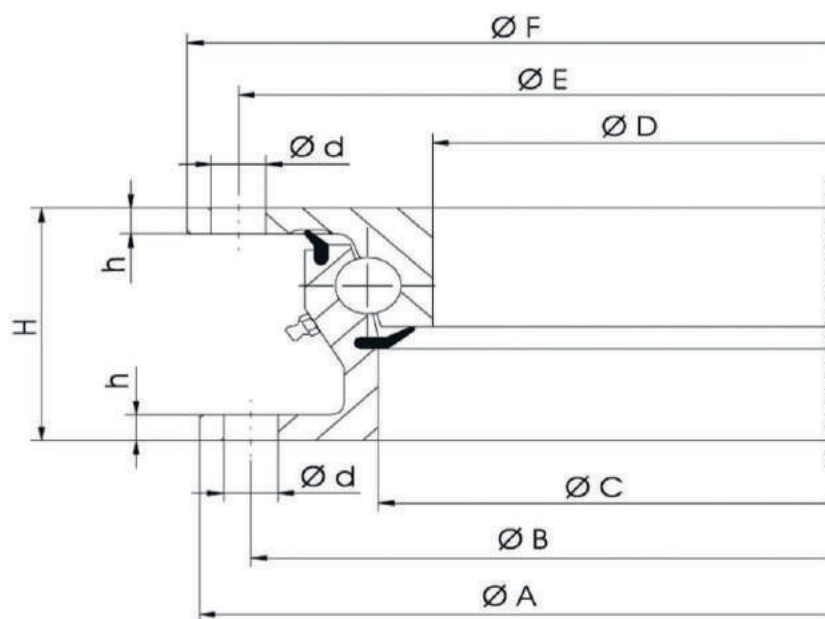



# BD

Ralle a sfera doppia  
Double-row ball race

## Dati tecnici - Technical data

Codice Part number	Foratura Drilling [mm]	Carico assiale Axial load [kN]	A [mm]	B [mm]	C [mm]	D [mm]	E [mm]	F [mm]	d [mm]	h [mm]	H [mm]	Peso Weight [kg]
BD16101	1	160	994	-	872	832	-	1000	18	11	90	84
BD16100	-	160	994	960	872	832	974	1000	-	11	90	85
BD18110	-	180	1094	-	972	932	-	1100	-	11	90	95
BD20120	1	200	1194	-	1072	1032	-	1200	-	11	90	102
BD20121	1	200	1194	1160	1072	1032	1174	1200	18	11	90	104
BD20111	1	200	1095	1060	972	932	1074	1102	18	11	90	94

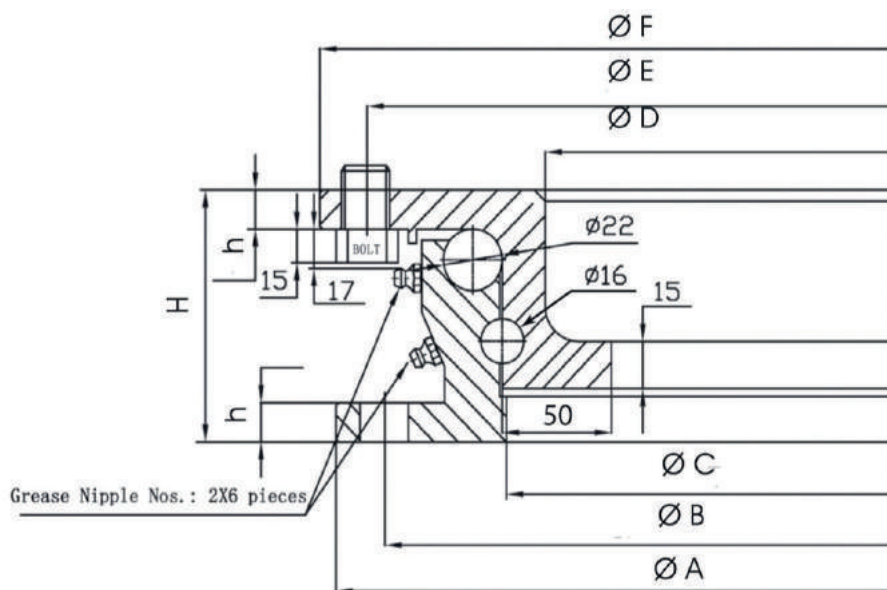

### FORATURA 1 - HOLE PATTERN 1

Anello inferiore - Lower ring - Unterer Ring  
Anneau inférieur - Нижнее кольцо

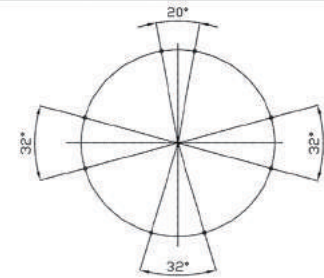

DIREZIONE DI MARCIA - DIRECTION OF TRAVEL  
FAHRTRICHTUNG - SENS DE LA MARCHE  
НАПРАВЛЕНИЕ ДВИЖЕНИЯ ↑

Anello superiore - Upper ring - Oberer Ring  
Anneau supérieur - Верхнее кольцо

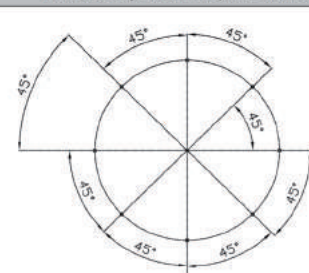

DIREZIONE DI MARCIA - DIRECTION OF TRAVEL  
FAHRTRICHTUNG - SENS DE LA MARCHE  
НАПРАВЛЕНИЕ ДВИЖЕНИЯ ↑



# K2V 2"

Perni di articolazione 2"  
Kingpins 2"

## Dati tecnici - Technical data

Codice Part number	T mm	E mm	Valore D D-Value kN	Omologazione Homologation		
				Classe Class	ECE R55	Tipo Type
K2VS000	6	35 +2 / -0	165	H50-X	E1 01 - 2289	50S15
K2VS100	8	35 +2 / -0				
K2VS200	10	33 +2 / -0				
K2VS300	12	33 +2 / -0			E1 01 - 2418	50S18
K2VS400	16	48				

## Dimensioni principali - Main dimensions

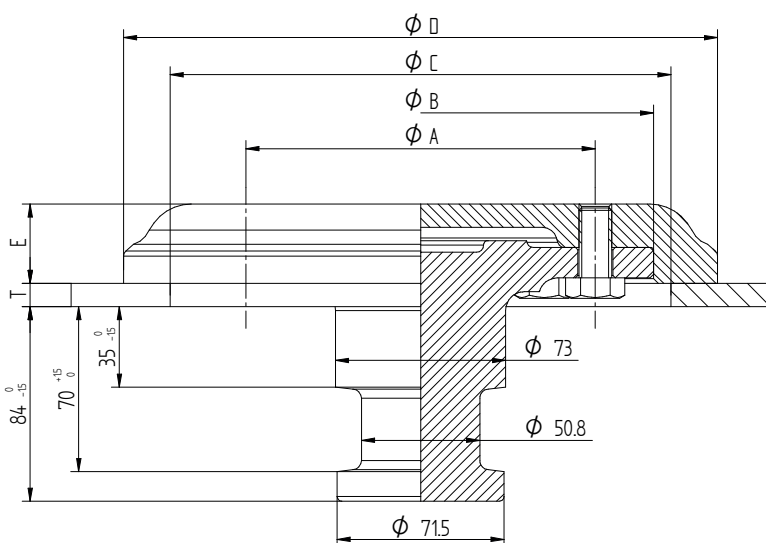

Codice Part number	Ø A mm	Ø B mm	Ø C mm	Ø D mm
K2VS000	150 - 8xM14	200	235	260
K2VS100				
K2VS200				
K2VS300				
K2VS400	180 - 8xM20	240	270	301,5

## Ricambi - Spare parts

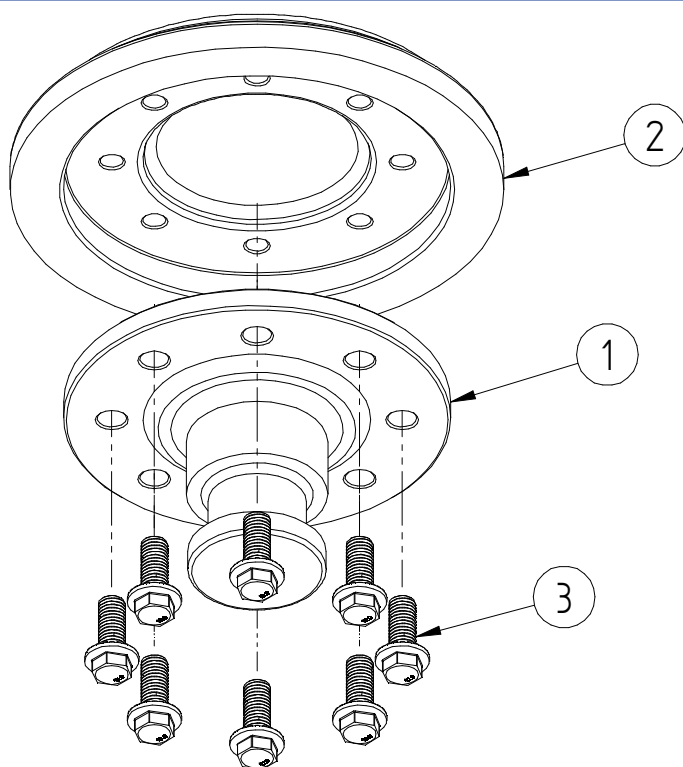

POS.		Codice Article number
1	6 mm	RKS0006
	8 mm	
	10 mm	
	12mm	
	16 mm	
2	6 mm	RKS0000
	8 mm	RKS0010
	10 mm	RKS0020
	12mm	RKS0030
	16 mm	RKS0040
3	6 mm	RKS0005
	8 mm	
	10 mm	
	12mm	
	16 mm	



# K3V 3,5"

Perni di articolazione 3,5"  
Kingpins 3,5"

## Dati tecnici - Technical data

Codice Part number	T mm	E mm	Valore D D-Value kN	Omologazione Homologation		
				Classe Class	ECE R55	Tipo Type
K3VS100	8	35 +2 / -0	165	H50-X	E1 01 - 2371	90S15
K3VS200	10	33 +2 / -0				
K3VS300	12	33 +2 / -0				
K3VS500	16	48	320		E1 01 - 2426	90S18

## Dimensioni principali - Main dimensions

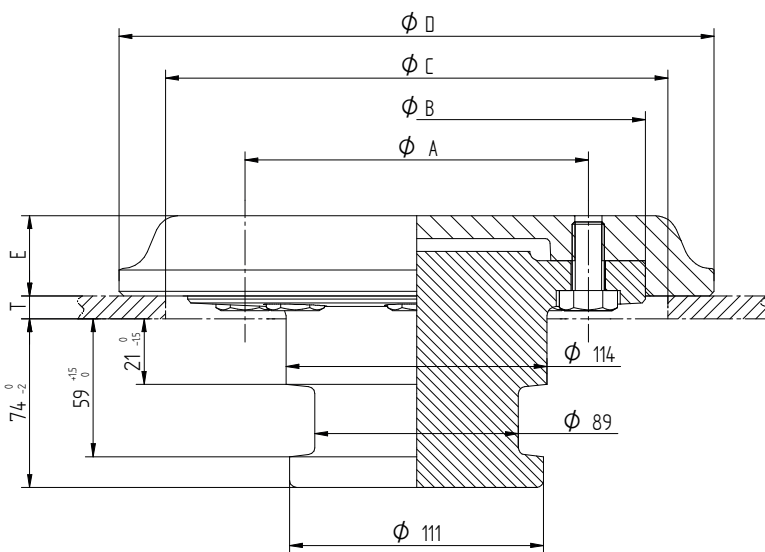

Codice Part number	Ø A mm	Ø B mm	Ø C mm	Ø D mm
K3VS100	150 - 8xM14	200	235	260
K3VS200				
K3VS300				
K3VS500	180 - 8xM20	240	270	301,5

## Ricambi - Spare parts

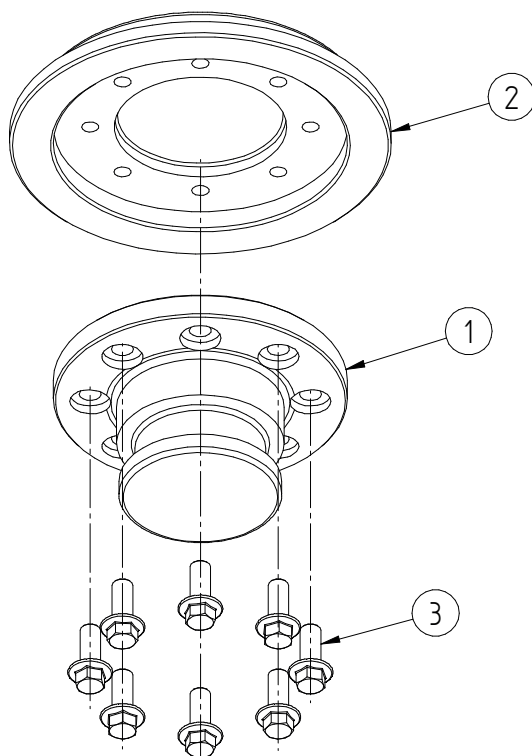

POS.		Codice Article number
1	8 mm	RKS0098
	10 mm	
	12 mm	
	16 mm	RKS0099
2	8 mm	RKS0010
	10 mm	RKS0020
	12mm	RKS0030
	16 mm	RKS0040
3	8 mm	RKS0005
	10 mm	
	12mm	
	16 mm	RKS0016



# LG3000

Sollevatori telescopici  
Landing gear

## Dati tecnici - Technical data

Tipo Type	Carico sollevabile per set Lifting capacity/set t	Carico statico per set Static load/set t	Velocità di sollevamento/giro Lift by one turn of handle		Forza manuale di sollevamento Crank force of handle		Peso Weight kg
			Marcia ridotta Low gear mm	Marcia veloce High gear mm	fino a 20 t up to 20 t	fino a 28 t up to 28 t	
LG3000	28	80	1	11	14 kg	17 kg	120

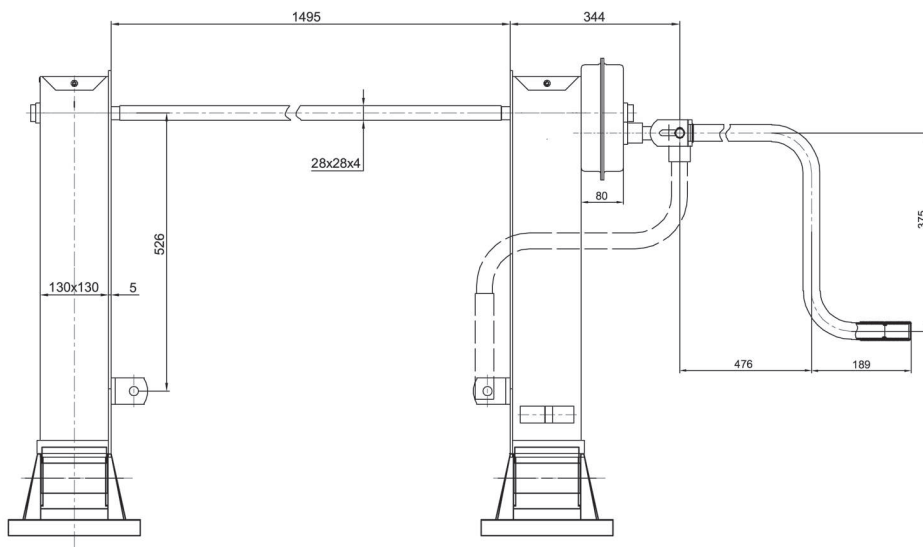
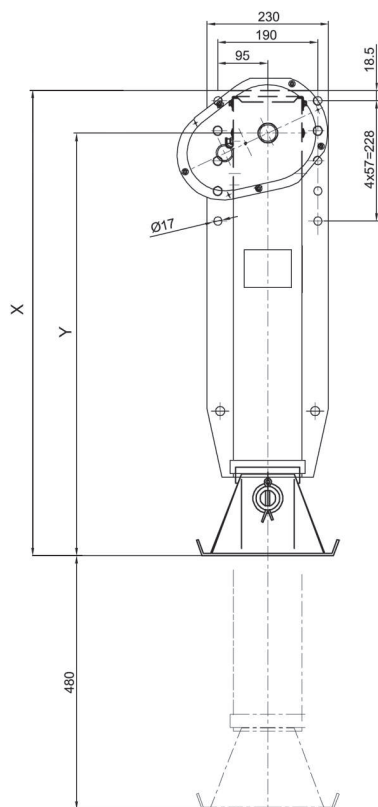

### Appoggi - Foot groups - Fußgruppen - Appuis - Опоры

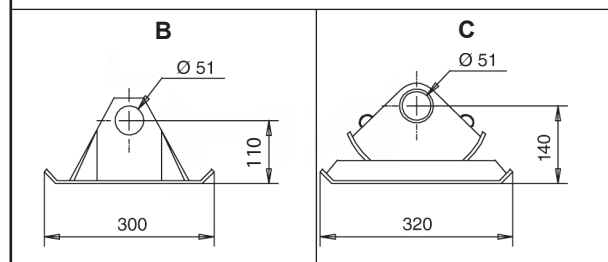

Tipo Type	Appoggi Foot groups	X mm	Y mm
LG3000	B	950	850
	C	960	880

**Crea il tuo codice:  
Create your part number:**

**LHD1 X M1**

Appoggi - Foot groups

Manovella - Crank  
handle





# LG4000

Sollevatori telescopici  
Landing gear

## Dati tecnici - Technical data

Tipo Type	Carico sollevabile per set Lifting capacity/set †	Carico statico per set Static load/set †	Velocità di sollevamento/giro Lift by one turn of handle		Peso Weight kg
			Marcia ridotta Low gear mm	Marcia veloce High gear mm	
LG4000	24	50	1	25	121,5

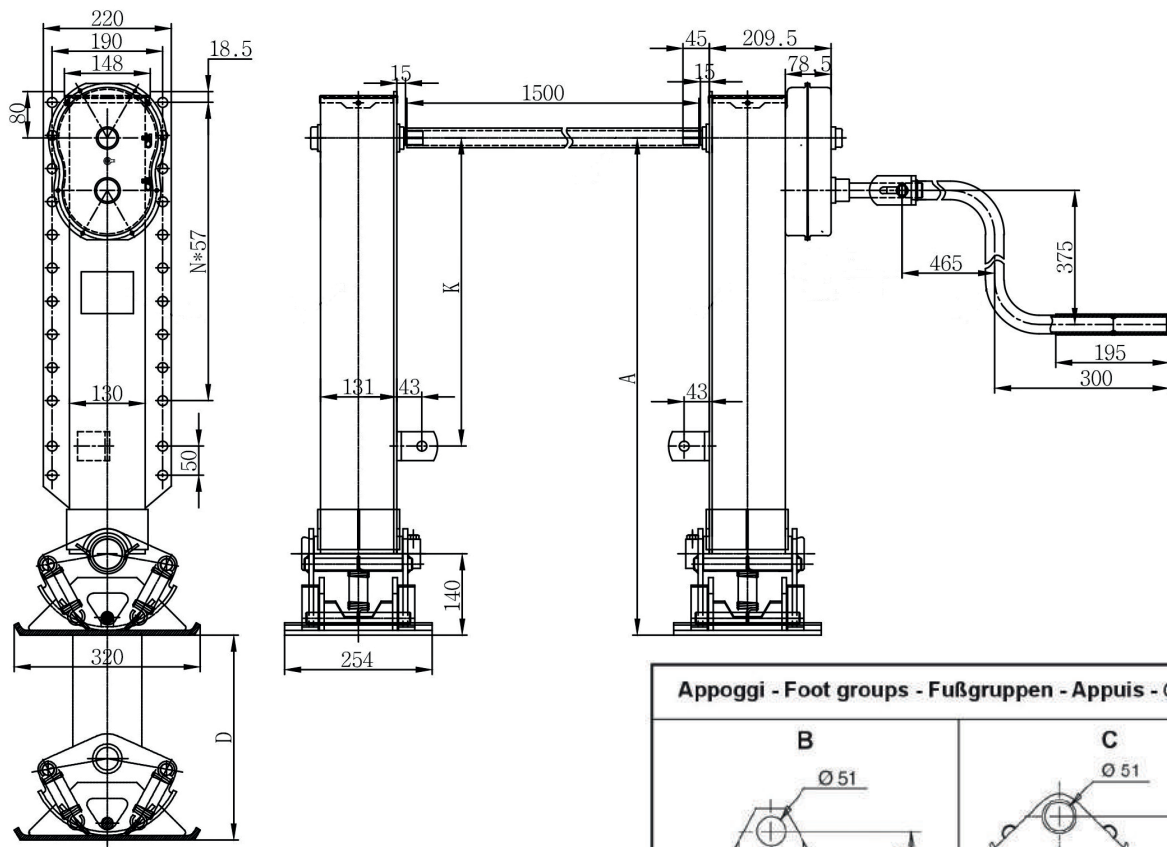

### Appoggi - Foot groups - Fußgruppen - Appuis - Опоры

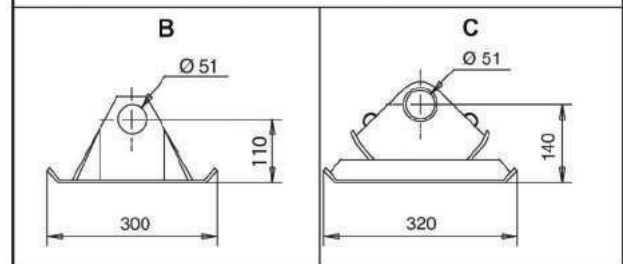

Tipo Type	Versioni Versions	A mm		D mm	K mm	N mm
		B	C			
LG4000	X	920	950	560	630	10
	Y	880	910	520	580	10
	W	830	860	470	530	9
	Z	790	820	430	480	9
	V	760	783	400	430	8
	U	710	733	350	380	8

Crea il tuo codice:  
Create your part number:

LG X 6 X M4

Versioni - Versions



Piastra di fissaggio - Mounting plate

Appoggi - Foot groups

Manovella - Crank handle

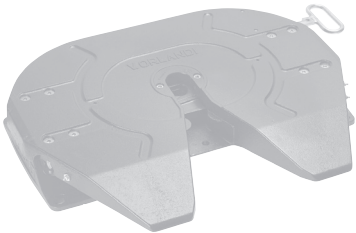
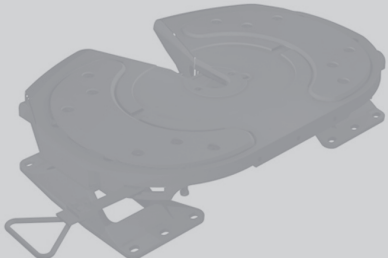

## Fuori produzione - Out of production

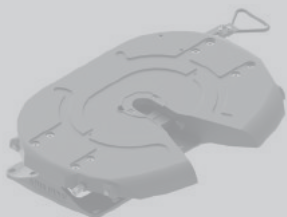
	Descrizione Description	Fuori produzione dal Out of production from
<p>RV02/E</p> 	<p>Ralla su tamponi Fifth wheels with rubber bearings</p>	2007
<p>RP10-T</p> 	<p>Ralla su tamponi Fifth wheels with rubber bearings</p>	2015
<p>RP10-P</p> 	<p>Ralla su perni Fifth wheel on pivot foot - bolt on</p>	2019
<p>RP50 - T</p> 	<p>Ralla su tamponi Fifth wheel on rubber foot - weld on</p>	2019



SAF-HOLLAND Group

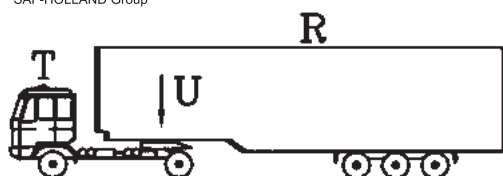

## Parametri tecnici dei sistemi di traino Technical parameters of towing system

### Ralle per semirimorchio e perni di articolazione

$$D = g \times \frac{0,6 \times T \times R}{T + R - U}$$

dove:

**D** = è definito come il carico teorico di riferimento per la determinazione della forza teorica orizzontale dinamica che il veicolo trainante ed il rimorchio si scambiano;

**g** = accelerazione di gravità che si assume pari a 9.81 m/s<sup>2</sup>;

**T** = è la massa del trattore che comprende il carico verticale trasmesso sulla ralla;

**R** = è la massa del semirimorchio;

**U** = è la parte di massa del semirimorchio che grava direttamente sulla ralla.

#### Esempio di calcolo

Trattore isolato con massa = 7 ton

Rimorchio con: R = 36 ton e U = 14 ton

Per il calcolo del valore D si dovrà considerare la massa del trattore pari a

$T = 7 + U = 7 + 14 = 21$  ton e quindi:

$$D = g \times \frac{0,6 \times 21 \times 36}{21 + 36 - 14} = 101 \text{ kN}$$

**I sistemi di traino omologati in accordo alla direttiva 94/20/CE devono riportare sulla targhetta i valori caratteristici (D, Dc, S, V e U) per i quali sono stati omologati.**

### Fifth wheels and kingpins

$$D = g \times \frac{0,6 \times T \times R}{T + R - U}$$

where:

**D** = Theoretical load for the determination of the theoretical horizontal dynamic force between towing vehicle and steering axle trailer;

**g** = Gravitational acceleration; 9.81 m/s<sup>2</sup>;

**T** = Weight of the towing vehicle including the vertical load on the fifth wheel;

**R** = Weight of the semitrailer;

**U** = That part of the semitrailer weight which is directly transmitted to the fifth wheel.

#### Example of calculation

Towing vehicle alone, weight 7 tons

Trailer with R = 36 tons and U = 14 tons

For the determination of the D-value the weight of the towing vehicle is calculated as follows:

$T = 7 + U = 7 + 14 = 21$  ton and therefore

$$D = g \times \frac{0,6 \times 21 \times 36}{21 + 36 - 14} = 101 \text{ kN}$$

**The towing systems homologated according to the directive 94/20/EC have to bear in the homologation plate the characteristic values (D, Dc, S, V and U) according to**









# SAF Holland

ORIGINAL PARTS



Emergency Hotline	+49 6095 301-247
Assistenza	+39 030 358 2722
Customer Service	+49 6095 301-602
Servizio Clienti	+39 030 358 2722
Spare Parts	+49 6095 301-301
Ricambi	+39 030 358 2722
Fax	+49 9095 301-494
	+39 030 358 2262



[www.safholland.com](http://www.safholland.com)  
[originalparts@safholland.de](mailto:originalparts@safholland.de)



[www.orlandi.it](http://www.orlandi.it)  
[orlandi@orlandi.it](mailto:orlandi@orlandi.it)

1990-481 D Subject to technical changes without prior notice



V.ORLANDI S.p.A.  
 25020 Flero (BS) Italy - Via Quinzano, 3  
 Tel. +39 030 358 27 22 - Fax +39 030 35822 62  
 E-mail: [orlandi@orlandi.it](mailto:orlandi@orlandi.it)

